

General construction technique permit

Public-law institution jointly founded by the
federal states and the Federation

**Technical authority granting approvals
and permits for construction products
and construction techniques**

Date: 7 Mar 2022 Reference number:
I 25-1.21.8-8/21

Number:
Z-21.8-2136

Applicant:
EJOT Sormat Oy
Harjutie 5
21290 RUSKO
FINLAND

Validity
from: **7 March 2022**
to: **7 March 2027**

Subject of decision:
Sormat screw anchor S-CSA+ for temporary fastening in concrete

The subject named above is herewith granted a general construction technique permit (*allgemeine Bauartgenehmigung*).
This decision contains five pages and four annexes.

Translation authorised by DIBt

DIBt

I GENERAL PROVISIONS

- 1 The general construction technique permit confirms the fitness for application of the subject concerned within the meaning of the Building Codes of the federal states (*Landesbauordnungen*).
- 2 This decision does not replace the permits, approvals and certificates required by law for carrying out construction projects.
- 3 This decision is granted without prejudice to the rights of third parties, in particular private property rights.
- 4 Notwithstanding further provisions in the 'Special provisions', copies of this decision shall be made available to the installer of the subject concerned. Furthermore, the installer of the subject concerned shall be made aware of the fact that this decision must be made available at the place of application. Upon request, copies of the decision shall be provided to the authorities involved.
- 5 This decision shall be reproduced in full only. Partial publication requires the consent of DIBt. Texts and drawings in promotional material shall not contradict this decision. In the event of a discrepancy between the German original and this authorised translation, the German version shall prevail.
- 6 This decision may be revoked. The provisions contained herein may subsequently be supplemented and amended, in particular if this is required by new technical findings.
- 7 This decision is based on the information and documents provided by the applicant on the subject concerned during the permit procedure. Alterations to this basis are not covered by this decision and shall be notified to DIBt without delay.

II SPECIAL PROVISIONS

1 Subject concerned and field of application

1.1 Subject concerned

The subject concerned is the Sormat screw anchor (concrete screw) S-CSA+ (hereinafter referred to as anchor), size 14 mm, in accordance with European Technical Assessment ETA-20/0446 of 19 February 2021. The Sormat screw anchor S-CSA+ is a special screw made of galvanised steel with a hexagon head, countersunk head or pan head.

For anchoring, the fastener is screwed into a predrilled cylindrical drill hole. The special thread of the fastener cuts an internal thread into the member while setting. The anchorage is characterised by mechanical interlock of the special thread in the concrete.

The installed fastener is shown in Annex 1.

1.2 Field of application

The fastener may be used for anchoring in reinforced and unreinforced normal weight concrete with a minimum strength class of C20/25 and a maximum strength class of C50/60 in accordance with DIN EN 206-1:2001-07 'Concrete – Part 1: Definition, properties, production and conformity'. The screw may be fastened and loaded before the required characteristic concrete strength has been reached subject to verification in accordance with Section 2.3.1.

The fastener shall only be applied for temporary fastening of construction site equipment, such as shoring props, fall protection devices or scaffolds. After it has been unscrewed, the fastener may be reused in other drill holes. However, a drilled hole shall not be reused after the fastener has been removed. Reusability of the fastener shall be checked prior to every use, both visually as well as with a sleeve gauge in accordance with Section 2.3.3. Installed fasteners shall be checked for visible damage (for example due to corrosion) on an ongoing basis and replaced if required.

The fastener may be used in cracked and uncracked concrete.

The fastener is intended for temporary use in internal and external conditions.

2 Provisions for planning, design and execution

2.1 Planning

The anchorages shall be planned in line with good engineering practice. Verifiable calculations and design drawings shall be prepared taking into account the loads to be anchored.

The design drawings shall contain the exact positions as well as size of the fasteners.

The minimum spacing of the fastener (spacing and edge distances) as well as the minimum member thicknesses in accordance with Annex 4 shall be observed.

2.2 Design

The present design provides the verification of the immediate local transmission of the anchor loads into the concrete. It shall be verified that the loads to be fastened are transferred in the member.

Additional loads that may arise in the screw, in the fixture or in the member in which the screw is fastened due to constraint (e.g. due to temperature fluctuations) shall be taken into account.

It shall be verified that the design action F_{Ed} does not exceed the design resistance F_{Rd} :

$$F_{Ed} \leq F_{Rd}$$

The design resistance values shall apply to all load directions irrespective of the failure mode. The resistances are listed in Annex 4 depending on the screw size, the embedment depth and the concrete strength $f_{ck,cube}$.

2.3 Execution

2.3.1 General

The fastener shall be installed in accordance with the design drawings prepared in accordance with Section 2.1.

The screw may be used in young concrete before the characteristic concrete strength $f_{ck,cube}$ of the nominal strength class has been reached. In this case, the concrete compressive strength shall have reached a value of $f_{ck,cube} \geq 10 \text{ N/mm}^2$.

The applicant of the construction technique or the executing company shall provide a declaration of conformity in accordance with Sections 16a(5) and 21(2) of the Model Building Code to confirm the conformity of the construction technique with this general construction technique permit.

2.3.2 Drilling and cleaning of drill hole

The drill hole shall be positioned taking into account the position of the reinforcement to ensure that the latter remains undamaged.

The hole shall be drilled perpendicular to the concrete surface using carbide masonry drill bits. The carbide masonry drill bit shall meet the specifications of the DIBt leaflet 'Characteristic values, requirements and tests for masonry drills with carbide drill bits used for drilling holes for anchoring' (*Kennwerte, Anforderungen und Prüfungen von Mauerbohrern mit Schneidkörpern aus Hartmetall, die zur Herstellung der Bohrlöcher von Dübelverankerungen verwendet werden*), January 2002. Compliance with the drill bit characteristic values shall be verified by means of a certification mark of the PMG Masonry Drill Bit Certification Board, Remscheid, Germany (see Leaflet, Section 5).

The nominal diameter of the drill bit, cutting diameter and hole depth shall correspond to the values given in Annex 3. The drilling dust shall be removed from the drilled hole.

If a hole is drilled incorrectly, a new hole shall be drilled at a distance of at least twice the depth of the incorrect hole.

2.3.3 Installation of screw

The fastener is only intended for temporary application in a single drilled hole. After it has been removed, it may be reused in other drilled holes. However, it may not be screwed into the same drilled hole for a second time.

Prior to every reuse, the wear of the thread shall be verified with an appropriate sleeve gauge. The fastener shall only be reused under the condition that it will penetrate the sleeve only so far that it does not protrude at the rear of the sleeve (see Annex 2). Screws which are visibly damaged, e.g. due to corrosion, shall not be reused.

The fastener may be screwed in using an impact screw driver.

To prevent the screw from spinning, the screw driver with a power output in the upper range shall be equipped with an automatic cut-off device, e.g. via a depth stop.

The fastener is installed correctly if

- the base plate (fixture) is screwed flush against the concrete without an intermediate layer,
- the fastener head is fully in contact with the base plate,
- the fastener cannot easily be turned further,
- the embedment depth h_{nom} is adhered to.

2.3.4 Inspection of execution

During the installation of the fastener, the contractor commissioned with the anchoring or the site manager assigned by him or her or a competent representative of the site manager shall be present at the construction site. They shall ensure that the work is carried out properly.

During the installation of the fasteners, the site manager or the site manager's representative shall document that the existing concrete strength in accordance with Section 2.3.1 and the proper installation of the fastener have been verified. The installed fastener shall be checked regularly by the site manager or his or her representative in accordance with Section 1.2. The results shall be recorded.

The records shall be available at the construction site during the construction period and shall be submitted to the inspection supervisor upon request. As is the case with the delivery notes, they shall be kept by the executing company for a minimum of 5 years after completion of the project.

Dipl.-Ing. Beatrix Wittstock
Head of Section

Drawn up by
Tempel

Product after installation

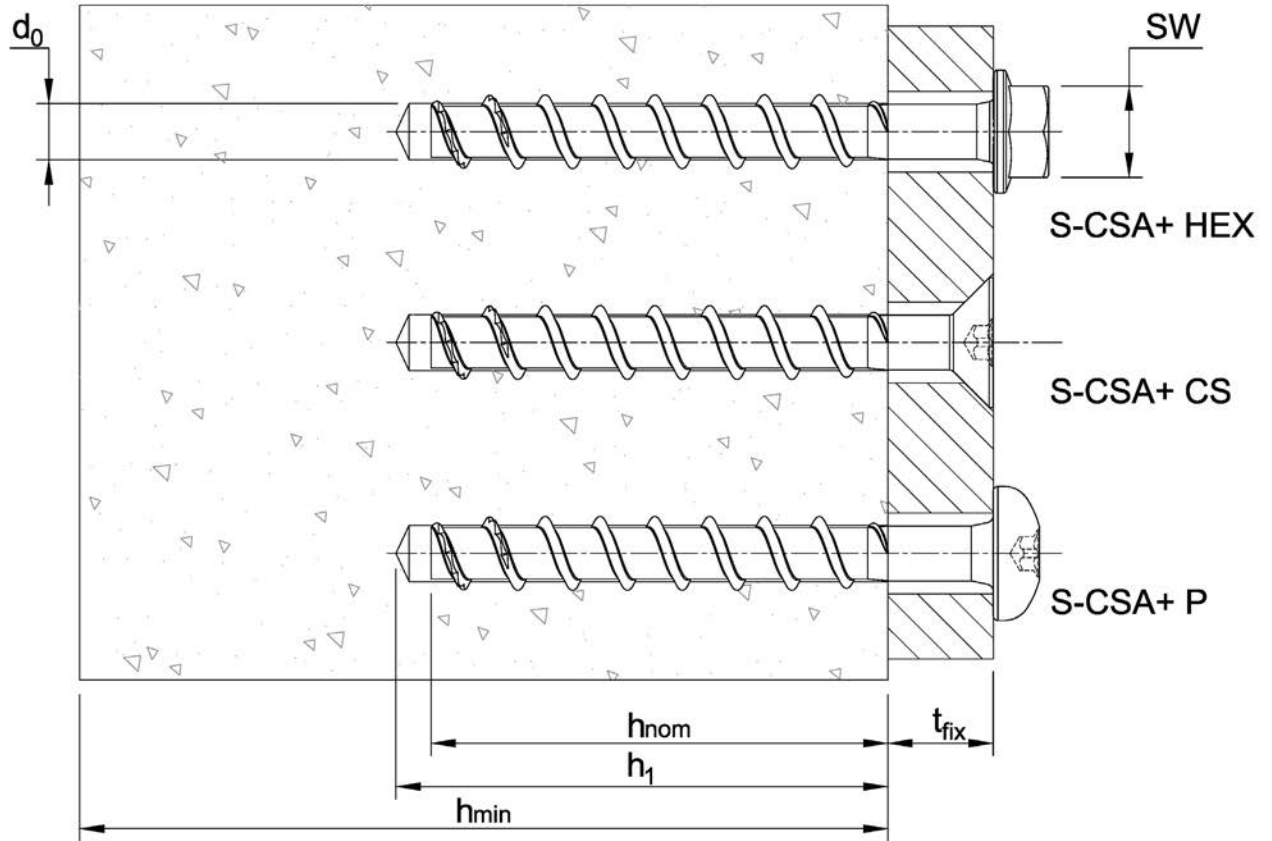

d_0 = nominal diameter of drill hole
 d_f = diameter of clearance hole
 t_{fix} = thickness of fixture
 h_{nom} = nominal embedment depth
 h_1 = depth of drill hole
 h_{min} = minimum thickness of concrete member

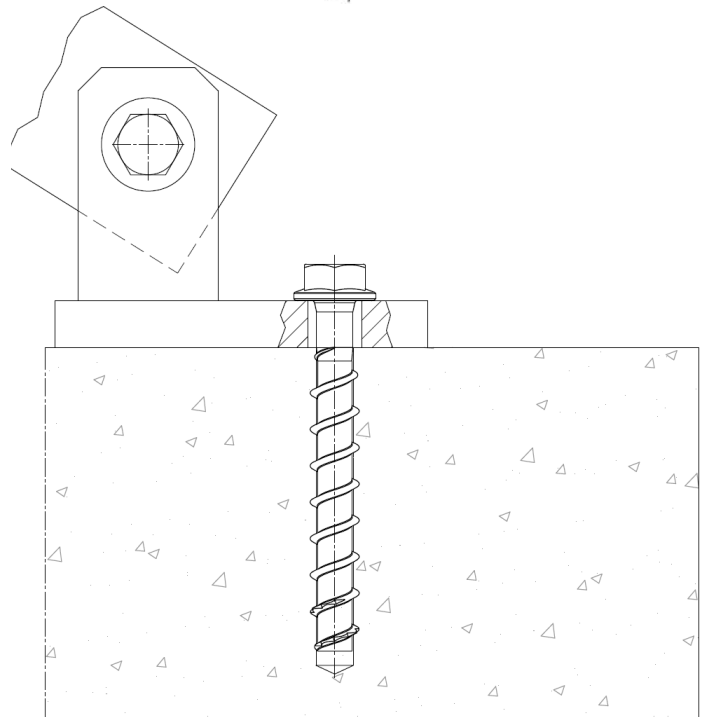

Sormat screw anchor S-CSA+ for temporary fastening in concrete

Product description
 Installed condition

Annex 1

Table 1: Specification and marking

Anchor size		S-CSA+ 14	
Nominal embedment depth	h_{nom}	[mm]	65 115
Outer thread diameter	d_{th}	[mm]	16,55
Core diameter	d_k	[mm]	13,00
Shaft diameter	d_s	[mm]	13,40
Cross section	A_s	[mm ²]	132,7

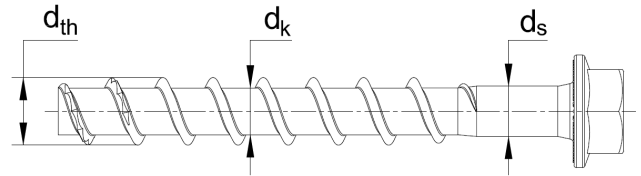

Nominal size and screw length
S-CSA+ : Sormat Concrete Screw Anchor

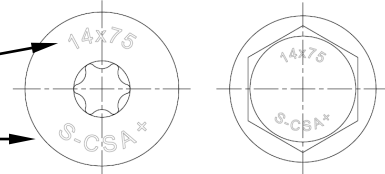

Types

Hexagonal head version with integrated washer
S-CSA+ HEX

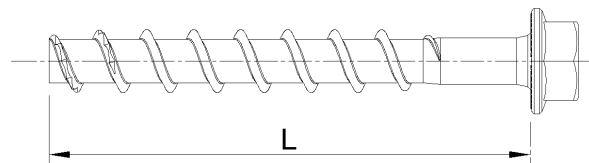
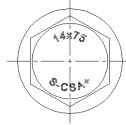

Countersunk head version with T-drive
S-CSA+ CS

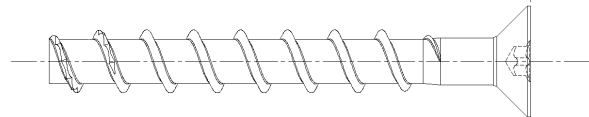

Pan head version with T-drive
S-CSA+ P

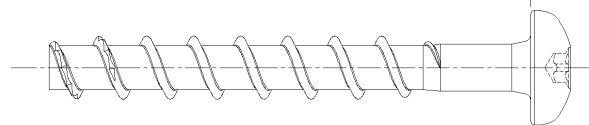

Gauge

Gauge inner diameter d_c 15,5 [mm]
Length l_c 40,0 [mm]

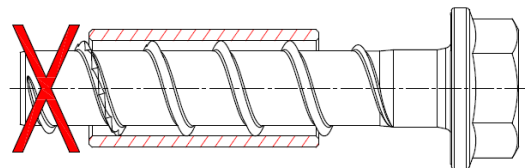
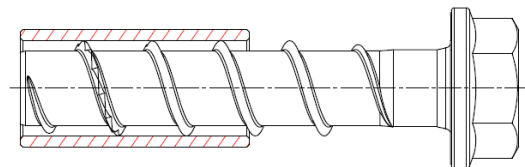
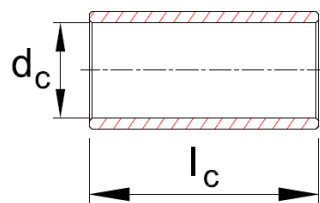

Sormat screw anchor S-CSA+ for temporary fastening in concrete

Dimensions and specifications
Reuseability

Annex 2

Table 2: Installation parameters and instruction

Anchor size			S-CSA+ 14	
Nominal embedment depth	h_{nom}	[mm]	65	115
Nominal diameter of drill hole	d_0	[mm]	14	
Diameter of cutting drill bit	$d_{cut} \leq$	[mm]	14,5	
Depth of drill hole	$h_1 \geq$	[mm]	75	125
Diameter of clearance hole	d_f	[mm]	17 - 18	
Effective embedment depth	h_{ef}	[mm]	49,3	91,8

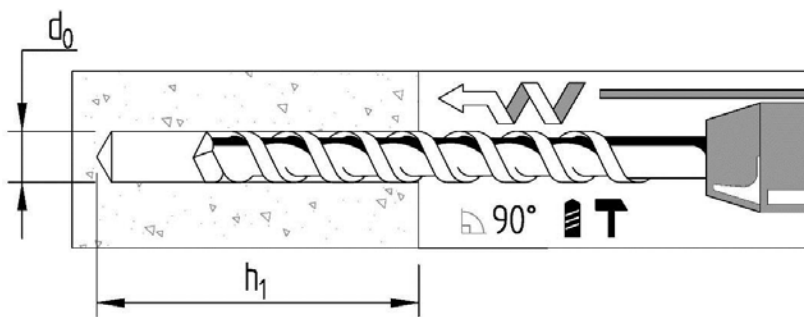

Make a cylindrical hole.

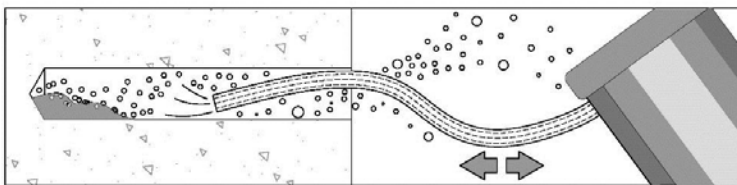

Clean the hole.

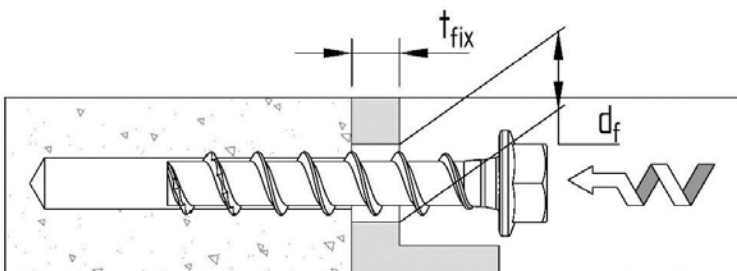

Install the screw anchor by impact screw driver or torque wrench.

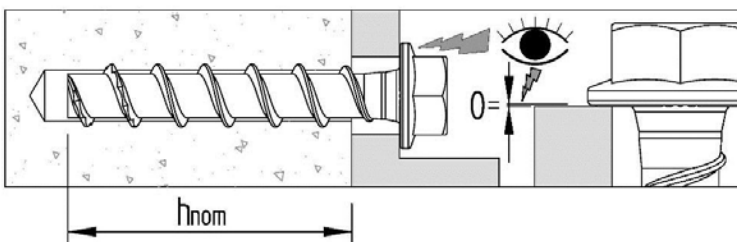

Ensure that the screw anchor head fully rests on the fixture without any gap and is not damaged.

Sormat screw anchor S-CSA+ for temporary fastening in concrete

Installation parameters and instruction

Annex 3

Table 3: Min. thickness of concrete member, min. spacing and edge distances in cracked and uncracked concrete

Anchor size		S-CSA+ 14		
Nominal embedment depth	h_{nom}	[mm]	65	115
Min. thickness of concrete member	h_{min}	[mm]	120	150
Min. spacing distance	s	[mm]	297	552
Min. edge distance	c_1	[mm]	99	184
Min. edge distance	c_2	[mm]	149	276

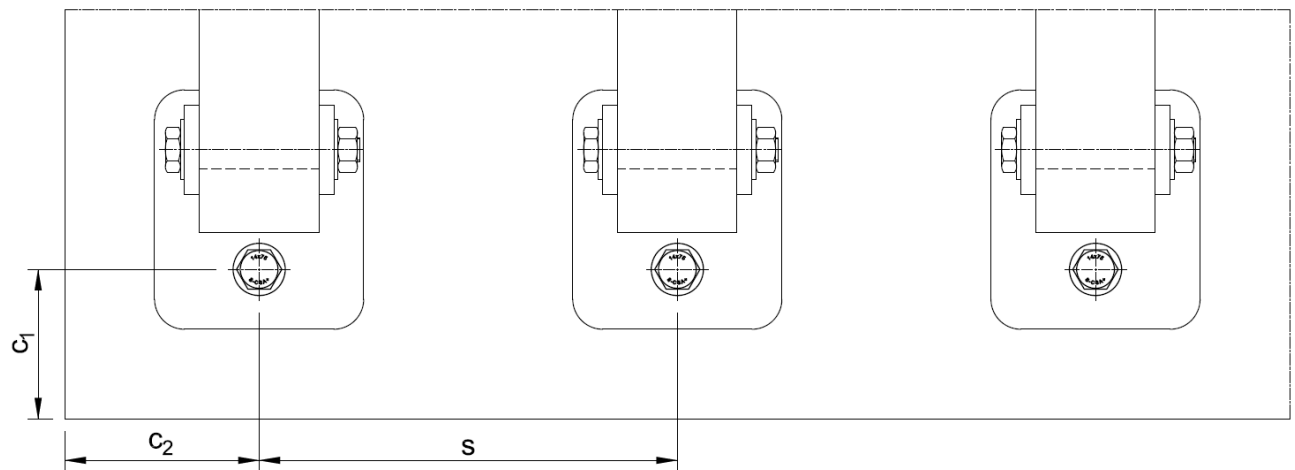

Table 4: Design resistance for all load directions in cracked and uncracked concrete

Anchor size		S-CSA+ 14		
Nominal embedment depth	h_{nom}	[mm]	65	115
Design resistance for concrete with a compressive strength $f_{ck,cube} \geq 10 \text{ N/mm}^2$	$F_{Rd}^{1)}$	[kN]	2,7	6,7
Design resistance for concrete with a compressive strength $f_{ck,cube} \geq 15 \text{ N/mm}^2$	$F_{Rd}^{1)}$	[kN]	3,0	8,0
Design resistance for concrete with a compressive strength $f_{ck,cube} \geq 20 \text{ N/mm}^2$	$F_{Rd}^{1)}$	[kN]	3,0	9,3
Design resistance for concrete with a compressive strength $f_{ck,cube} \geq 25 \text{ N/mm}^2$	$F_{Rd}^{1)}$	[kN]	3,3	10,0

¹⁾ Design resistance incl. partial safety factor.

Sormat screw anchor S-CSA+ for temporary anchoring in concrete

Performance: Min. thickness of concrete member, min. spacing and edge distances, design resistance

Annex 4