



Van der Valk Solar Systems B.V.

Manual: ValkPro+ South 10°

Version: v1.0.4
Date: 7-2-2020

VAN DER VALK



Disclaimer

The project report is the result of the use of the online calculation tool of Van der Valk Solar Systems B.V., called the "ValkPVplanner", which project report shows you specific information about your project such as, amongst other, a project drawing and ballast plan for flat roofs (the "Project Report"). This ValkPVplanner and the Project Report(s) derived from this ValkPVplanner are composed with the greatest possible care. Nonetheless, it is possible that some information might not be entirely correct as the results for each Project Report can be based on default values entered into this ValkPVplanner by you, which values always need to be checked and validated by you. The instructions provided in this Project Report must be strictly observed at all times, in addition to and in conjunction with the installation manual provided by us (the "Installation Manual"), and vice versa.

At all times all currently applicable structural, safety and building regulations must be observed when using the ValkPVplanner and/or Installation Manual. The building in question will be subject to a load as a result of the solar mounting system installed/mounted. Solar mounting systems installed on roofs will be exposed to wind and snow. Therefore, you are at all times responsible to obtain and use a design calculation to establish whether or not the building will be able to withstand the (extra) load at all times. Where necessary, modifications need to be made by you. Van der Valk will not accept any form of liability upon you not having obtained and used such a required design calculation.

Flat roof systems should either be attached to the roof or need to be supported by ballast, to make sure that the solar mounting system is unable to be lifted, tipped over or slide. The ballast specified in the Project Report will be vital to ensure that the mounting system can be used. Flat roofs with an angle above 5 degrees must always be attached to the roof itself.

The calculations in the ValkPVplanner do not take into account obstacles in the near surrounding such as, for example, high buildings, cliffs and mountains. Restrictions also apply for the position of the solar mounting system on a roof. The solar panels must be installed at a certain distance from the edge of the roof as shown in the respective Project Report and the Installation Manual.

The standard warranty for pitched roof, flat roof and ground mount systems is 10 years, which can be extended under certain conditions. The guarantee provided is subject to the guarantee conditions stated in the general terms and conditions stipulated by Van der Valk Solar Systems B.V. Our terms and conditions shall apply to all our products at all times and can be found on our website: www.valksolarsystems.nl

Van der Valk Solar Systems B.V. does not accept any liability for any direct and/or indirect consequences of any act (or omission) ensuing from the information in or failure to observe the instructions provided in the Project Report and/or the Installation Manual and for possible incorrect results resulting from the use of this ValkPVplanner which was made available to you. The use of the ValkPVplanner, the derived Project Report and the Installation Manual will at all times be subject to Dutch law.

Please note

- This manual is not project specific.
- This manual is not legally binding.
- No right may be derived from this manual.
- Use this manual in combination with the ValkPVplanner project report.
- Check 'Datasheet Cable management' for cable suggestions.
- The system can be placed both in the middle zone and the edges/corners of the roof.
- Side plates are optional in the middle zone and mandatory in the edges/corners of the roof.
- The need of mass carriers depends on the amount of ballast needed or when the side plates are used.

Table of contents:

Disclaimer	Page 01
Table of contents	Page 02
Recommended tools for installing ValkPro+	Page 03
Required materials for ValkPro+ L10 [South]	Page 04 & 05
Pre-assembling roof carriers sets	Page 06
Placing roof carrier rows	Page 07
Placing ballast	Page 08 - 10
Mounting side panels	Page 12
Placing solar panels	Page 13
Mounting back panels	Page 14
Mounting micro inverter clamps	Page 15
Dilatations	Page 16
Cable management	Page 17 & 18
Specials	Page 19 - 21

Required tools for installing ValkPro+



Cordless drill

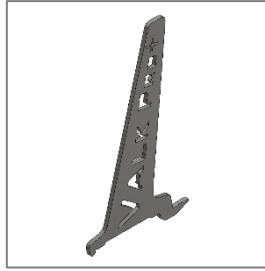

Disassembly key
(743000)

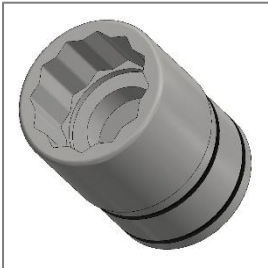

Socket 13mm

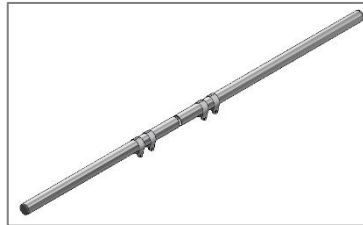

Alignment set
(743220)

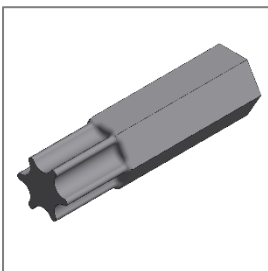

Torx bit T-30
(789530)

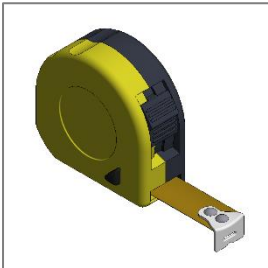

Measuring tape

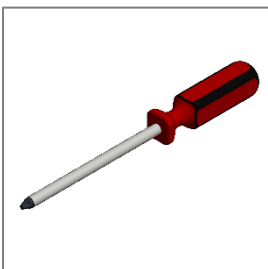

Screw driver (Ø4-6mm)
(use when aligning the roof carriers)

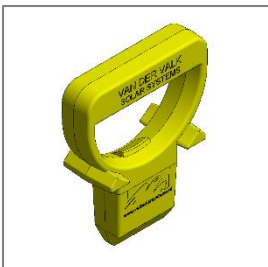

Alignment key roof
(739010)

Basic materials for installing ValkPro+ L10 [South]

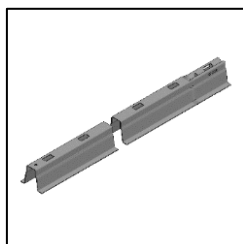

Galv. Roof carrier
(741801500)

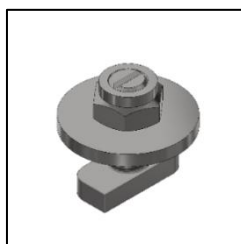

Coupling set
(774221)

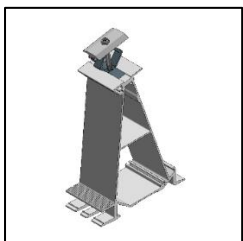

Aluminium Back foot middle
(724650)

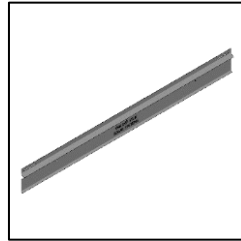

Galv. Back panel
(742510) - [1520-1720mm]
(742512) - [1720-1920mm]
(742515) - [1900-2100mm]

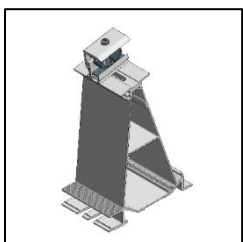

Aluminium Back foot side
(724651)



Ss. Thread forming bolt
(773320)

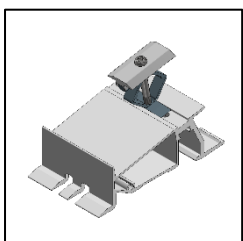

Aluminium Front foot middle
(724660)

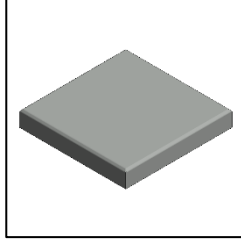

Concrete tile 9 kg (300x300x45mm)
(7506303045)

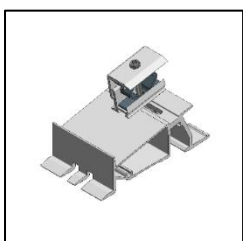

Aluminium Front foot side
(724661)

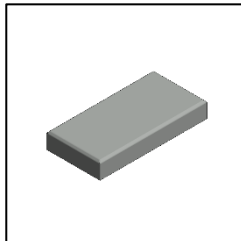

Concrete tile 4,5 kg (300x150x45mm)
(7506301545)

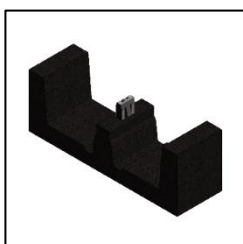

Rubber Tile carrier
(729622) - standard
(729623) - for PVC

For the 'optional' materials, see next page.

Optional materials:

The optional materials can be used to optimize the system to specific situations and wishes.

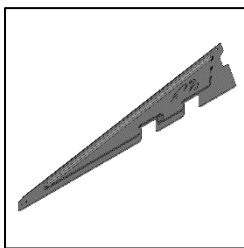

Galv. Universal side plate
742540

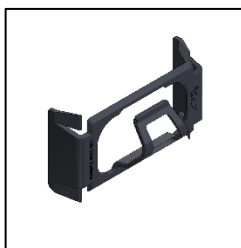

Plastic Cable clamp for ValkPro+
(732011)

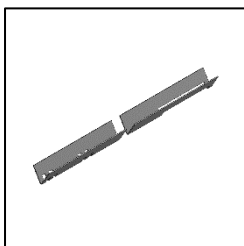

Galv. Mass carrier
(742550) - [1520-1720mm]
(742553) - [1720-1920mm]
(742555) - [1900-2100mm]

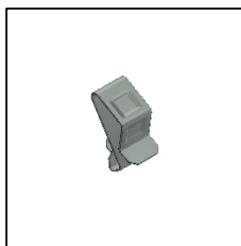

Ss. Cable clamp small
(732001)

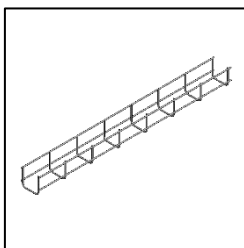

Cable basket 50x60mm
(76010050603000)

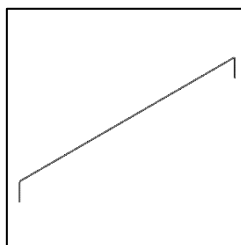

Galv. Dilatation wire
(732020)

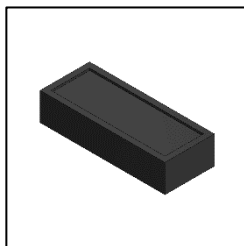

Rubber Elevation block (for gravel roofs)
(729627)

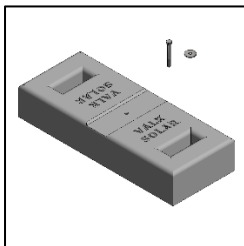

Mass block
(750520)

Pre-assembling roof carriers sets

It is possible to pre-assemble the aluminium feet and rubber tile carriers on the roof carriers before placing them on the roof. This can save a lot of time. The correct locations of the aluminium feet are indicated with the letter L on top of the roof carrier. The rubber tile carrier is placed in the second oblong hole in front of the aluminium back foot.

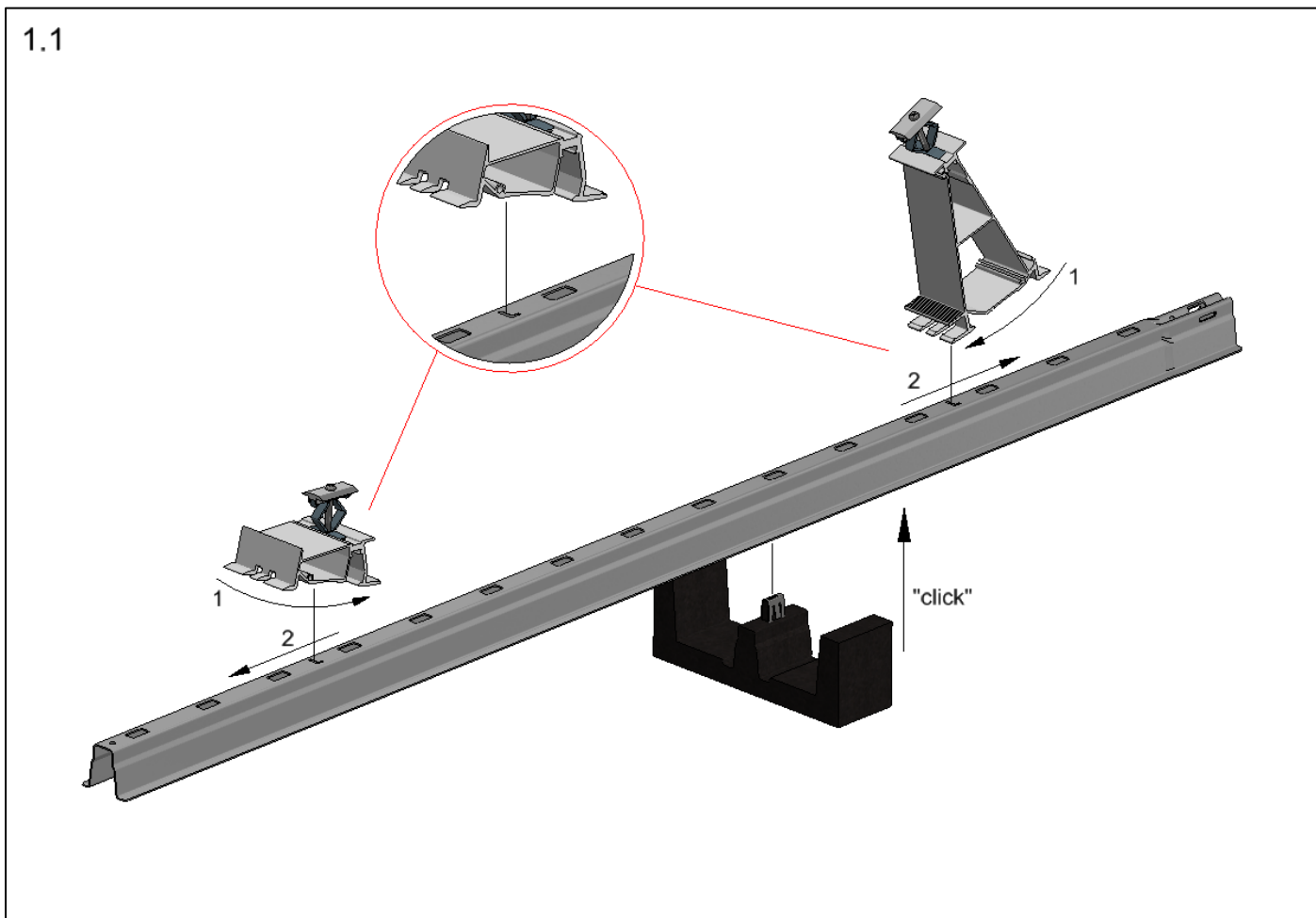

Side view

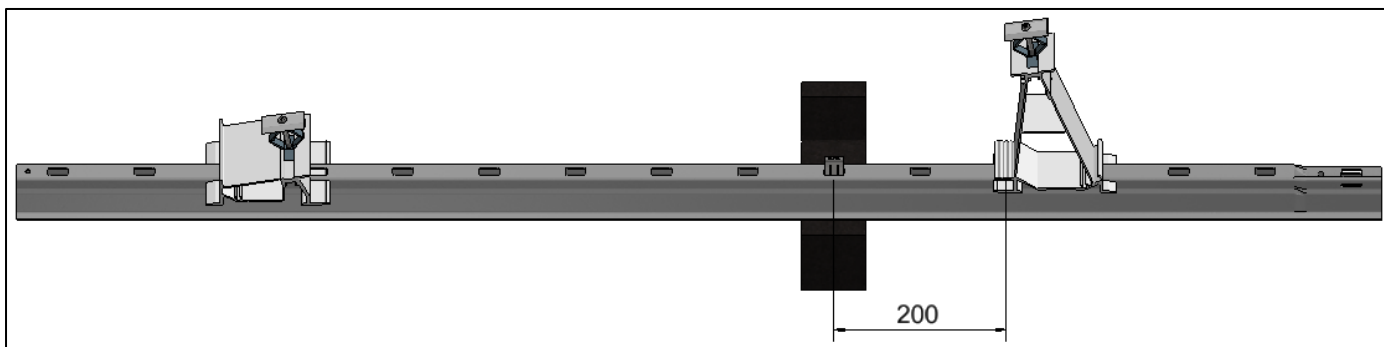

Placing roof carrier rows

Place the roof carriers on the roof in the desired layout or starting point. Place the new roof carrier over the reduced end of the other roof carrier. The roof carriers are then fastened with the coupling set. (see 1.3)

The center-to-center distance between the roof carrier rows depends on the panel size: panel size + 10mm. This progress can be simplified with the optional alignment tool (743220).

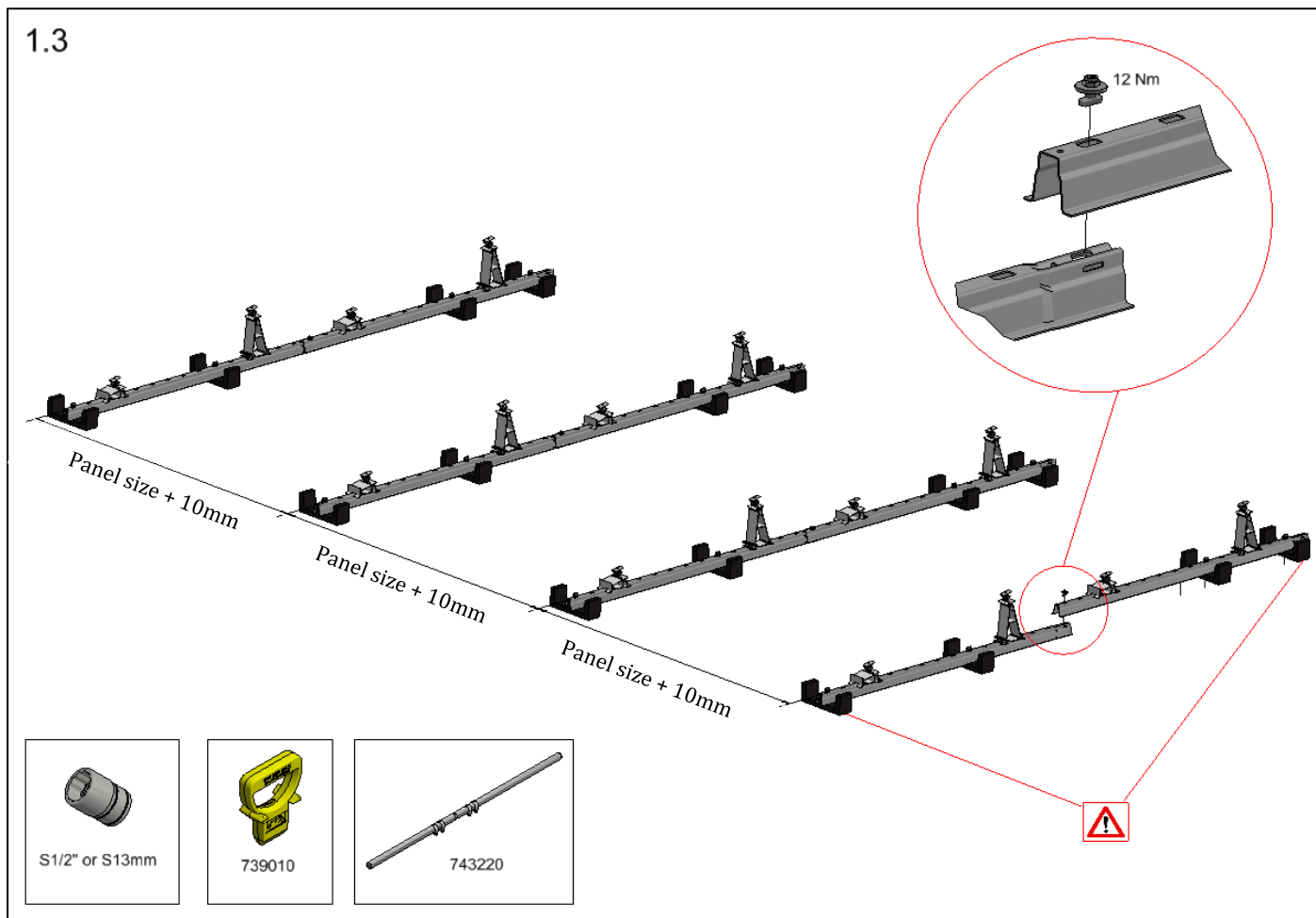

In the first and last oblong-hole of the roof carrier row (excl. Coupling) an extra rubber tile carrier must be placed.

Dilatation

The coupled system has to be dilated after certain measurements, this needs to be done because of the thermal expansion/contraction. For the South-North direction this is 60m, for the East-West direction this is 30m.

Tools for aligning roof carriers

Aligning the roof carriers can be simplified with the following tools:

Alignment key ValkPro+ (739010)

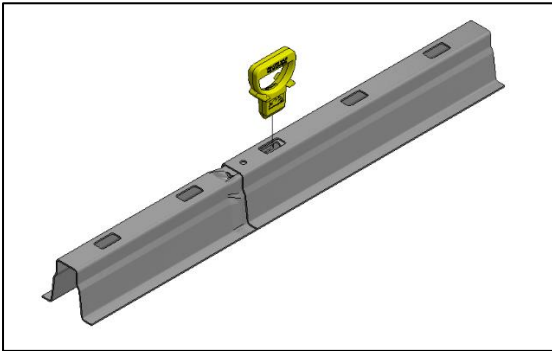

The alignment key can be used to align the oblong holes of the roof carriers.

Screw driver (Ø4-6mm)

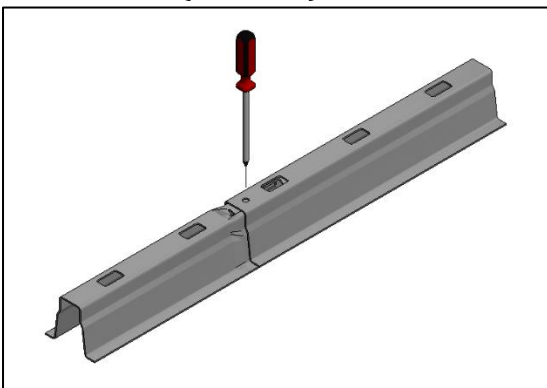

The screw driver can be used to align the oblong holes of the roof carriers.

Alignment set ValkPro+ (743220)

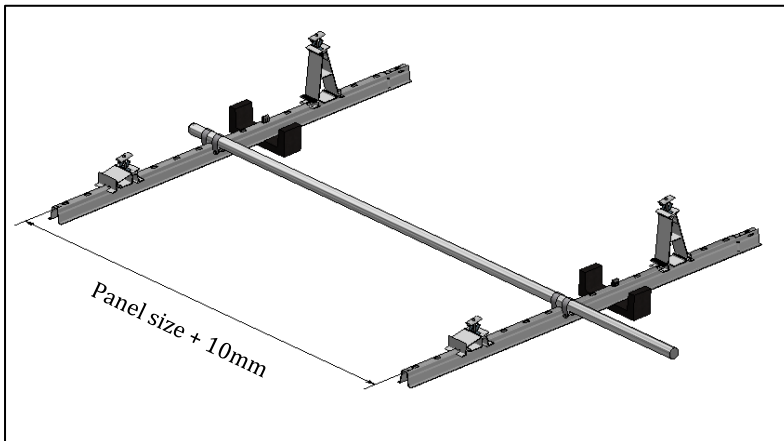

The alignment set can be used to make sure the roof carrier rows are placed at the correct pitch beside each other.

Placing ballast

The ballast can be placed on the rubber tile carriers or on the mass carriers (only when necessary). Check the project report from the ValkPVplanner for the required ballast per panel.

2.1

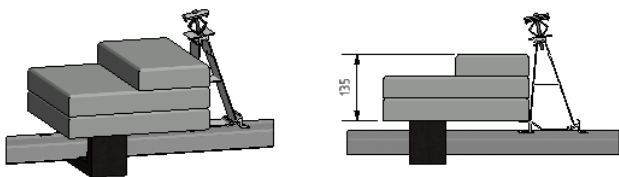
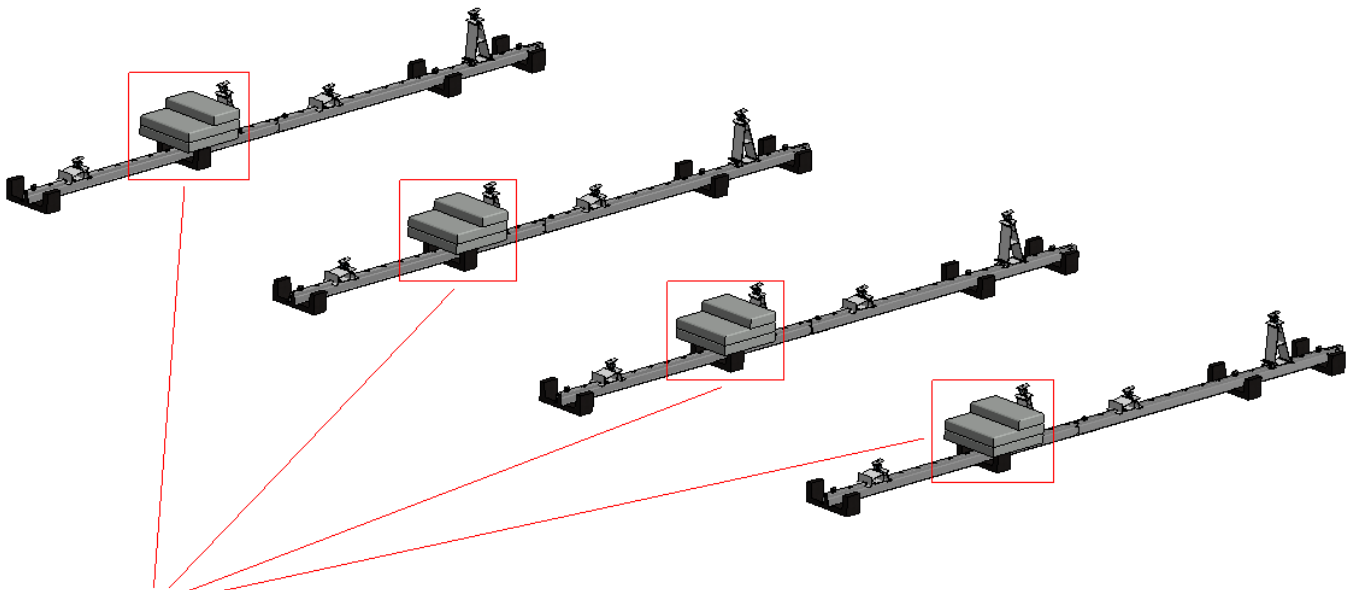

Max. no. of tiles on rubber tile carriers:
2,5 tiles (22,5 kg)

Mass carriers

If the ballast is over 2,5 tiles or the ballast cannot be placed due to a side panel the mass carriers are required. A mass carrier is placed on both sides of the rubber tile carrier, which creates the support for the tiles (see image 2.2).

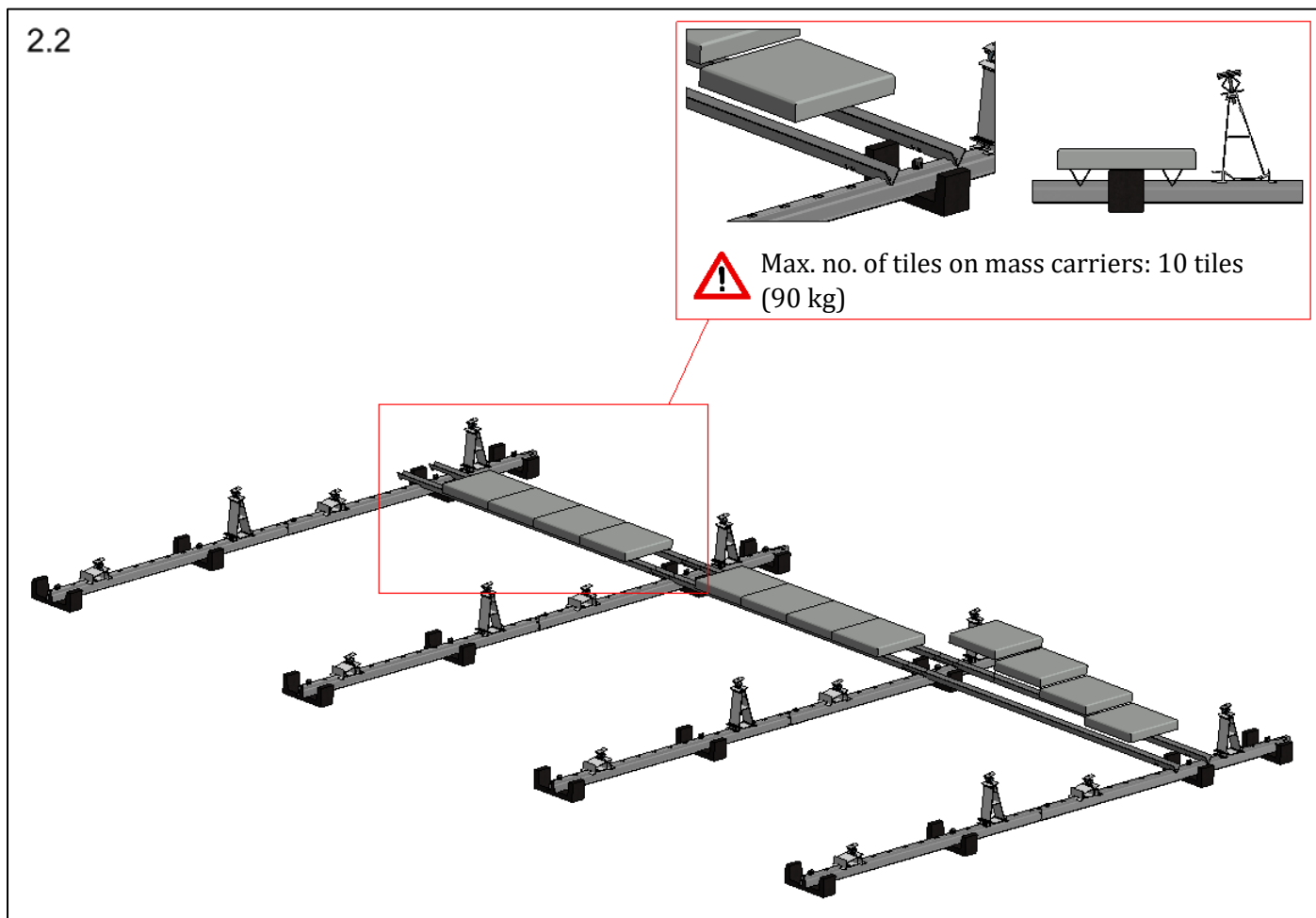

Dividing ballast

The ballast is placed according to the project report from the ValkPVplanner. Each project report indicates the required ballast per panel, but without mass carriers the ballast will be divided over the foundation points under the panel. In the next image is explained how the ballast should be divided over the different foundation points.

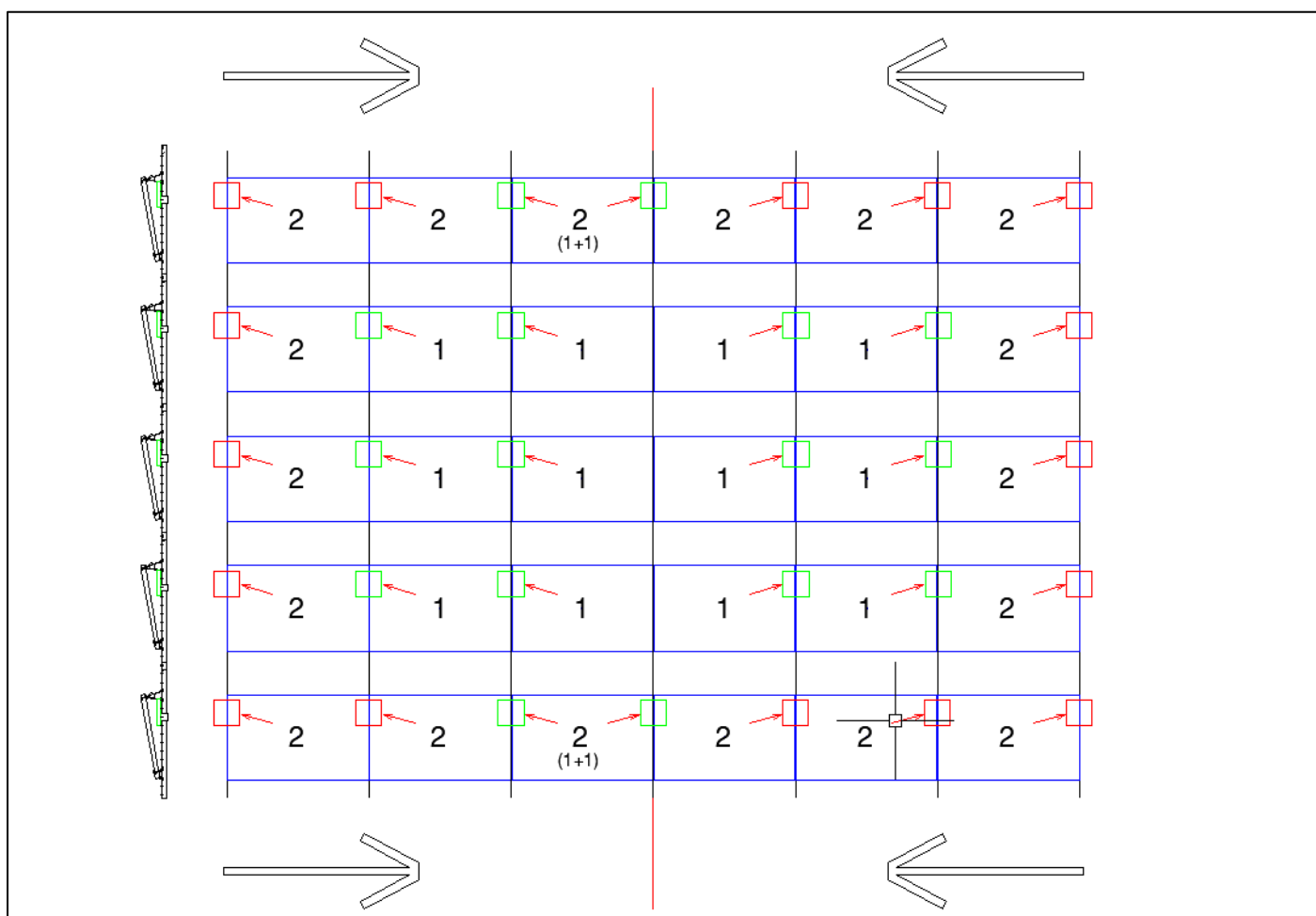

The required number of tiles is indicated in the panels (same as the project report). The ballast is always placed from the outside toward the inside of the system. Therefore the middle row of the system doesn't require any ballast (see red line), if possible there may be ballast placed in those foundation points.

Mounting side plates

In a standard system (middle zone only) the usage of side plates are optional. If a part of the system is placed under one of the following circumstances the side plates are mandatory:

- Panels are placed in the edge/corner zones of the roof.
- Roof height is >25m

Each side plate is mounted to the aluminium feet using 3 thread forming bolts. (see image 3.1)

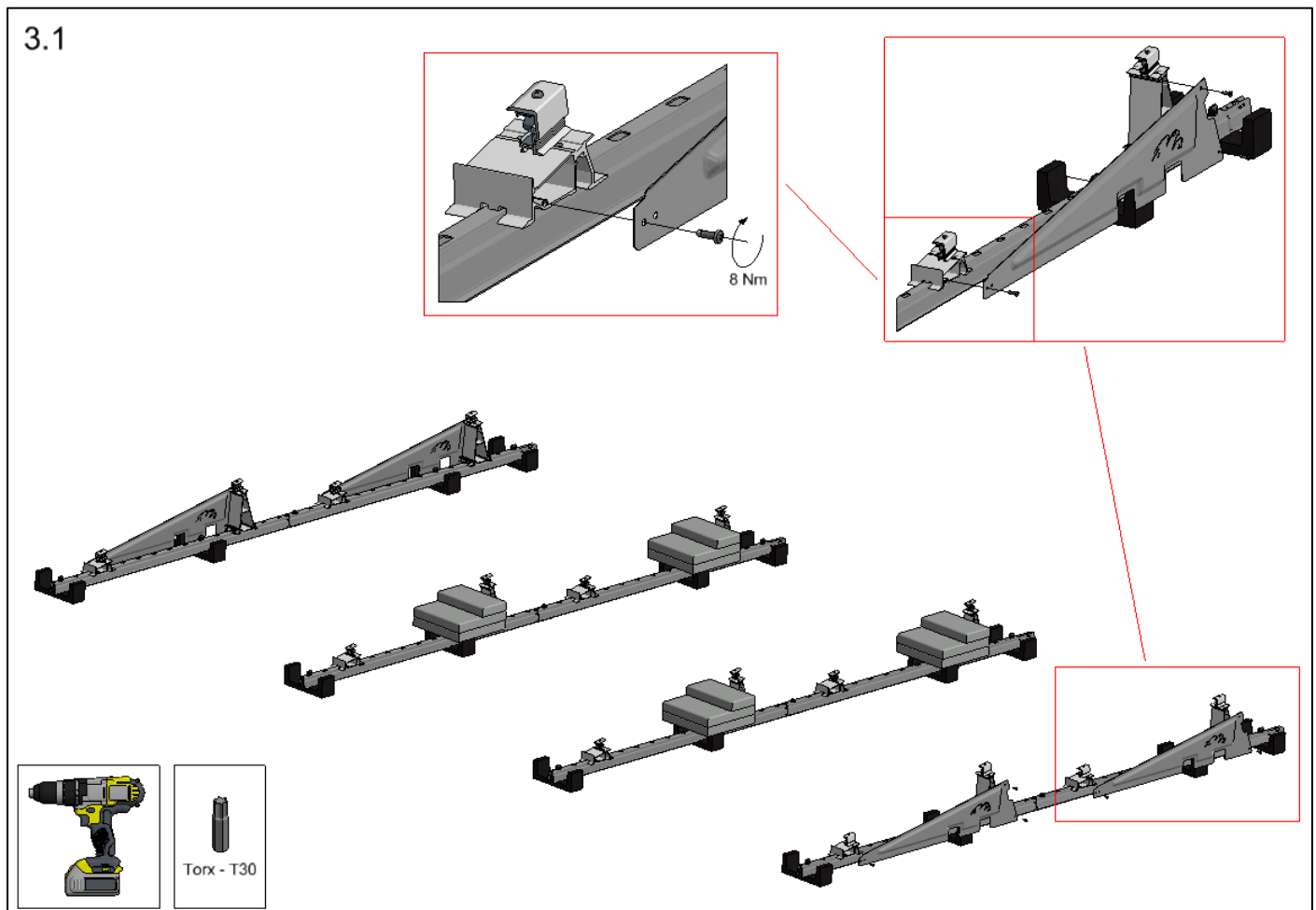

Placing panels

Place the panels over the frame and make sure all the clamps on the aluminium feet are fastened.

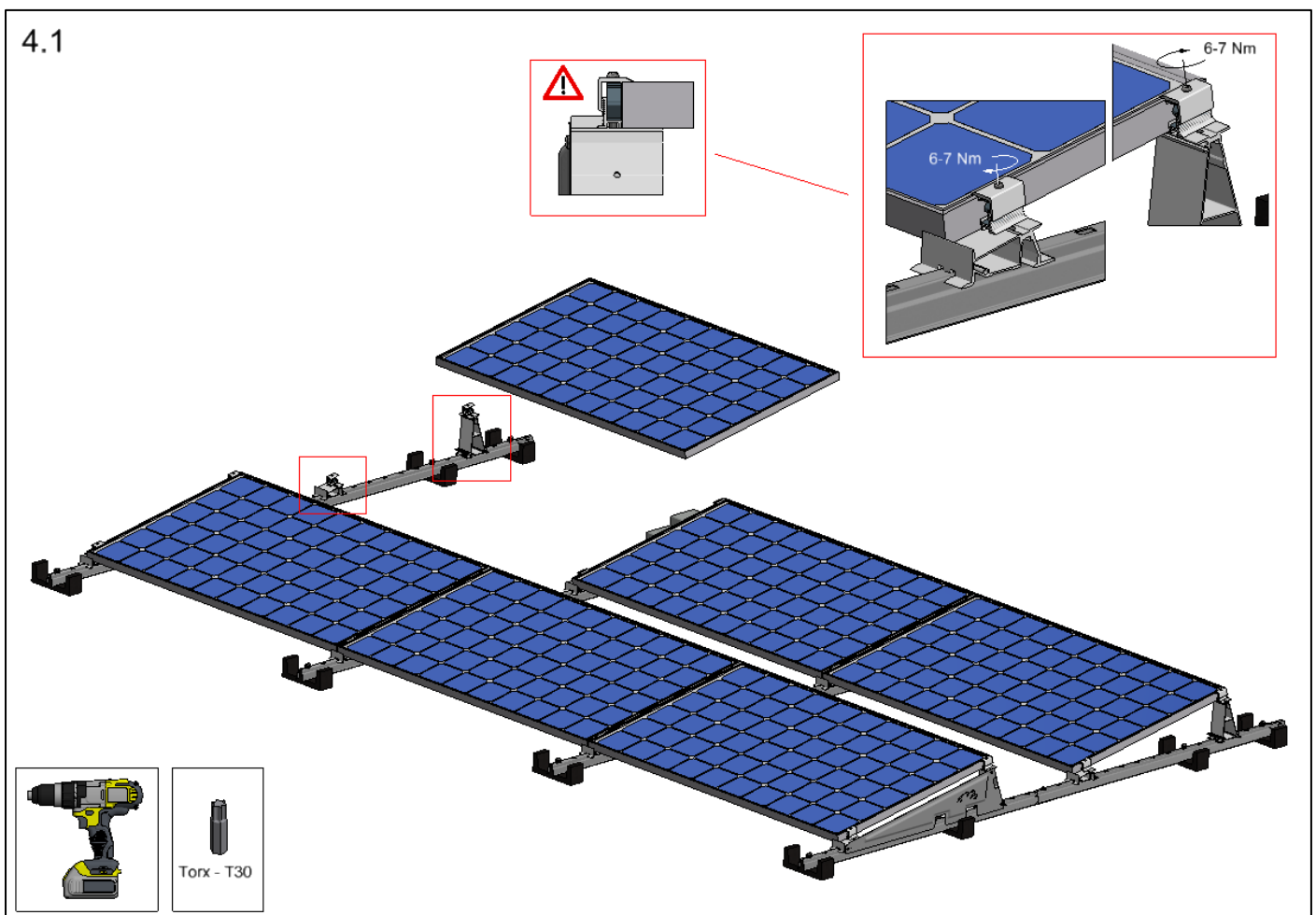

Make sure the end clamps are placed in the correct slot before they are fastened.

Mounting back panels

Each panel is provided with a back panel. The back panels are placed in the back feet and are fastened with the thread forming bolts. Also the back panels that overlay each other are fastened with 1 thread forming bolt.

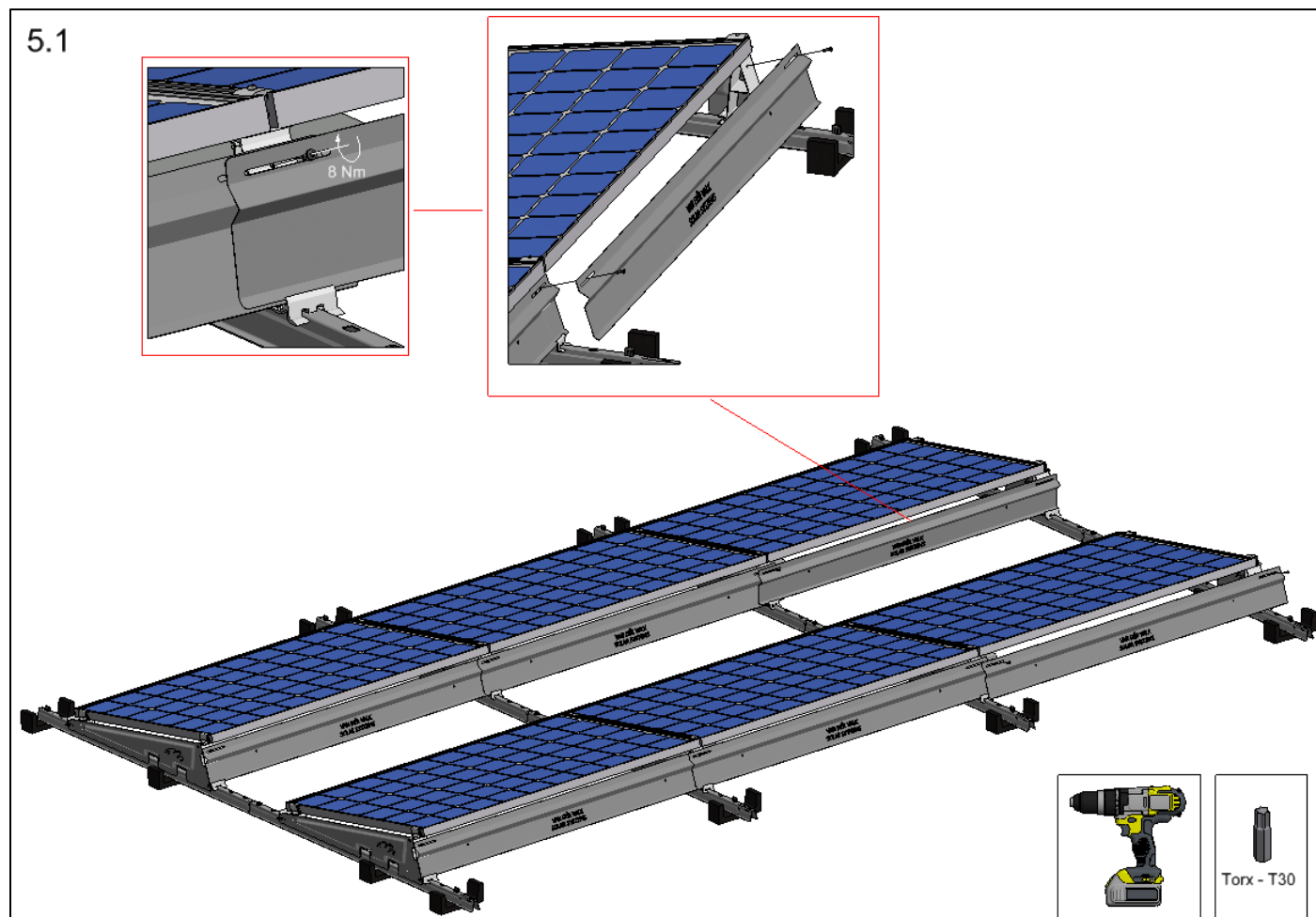

Mounting micro inverter clamps

The micro inverters will be fastened with the coupling pieces that are used to couple the roof carriers (774221). There are 2 locations where the micro inverter can be mounted.

First location: the micro inverter is mounted to the back panel. (see image 6.1, detail 1)

Second location: The micro inverter is mounted on the roof carrier. (see image 6.1, detail 2)

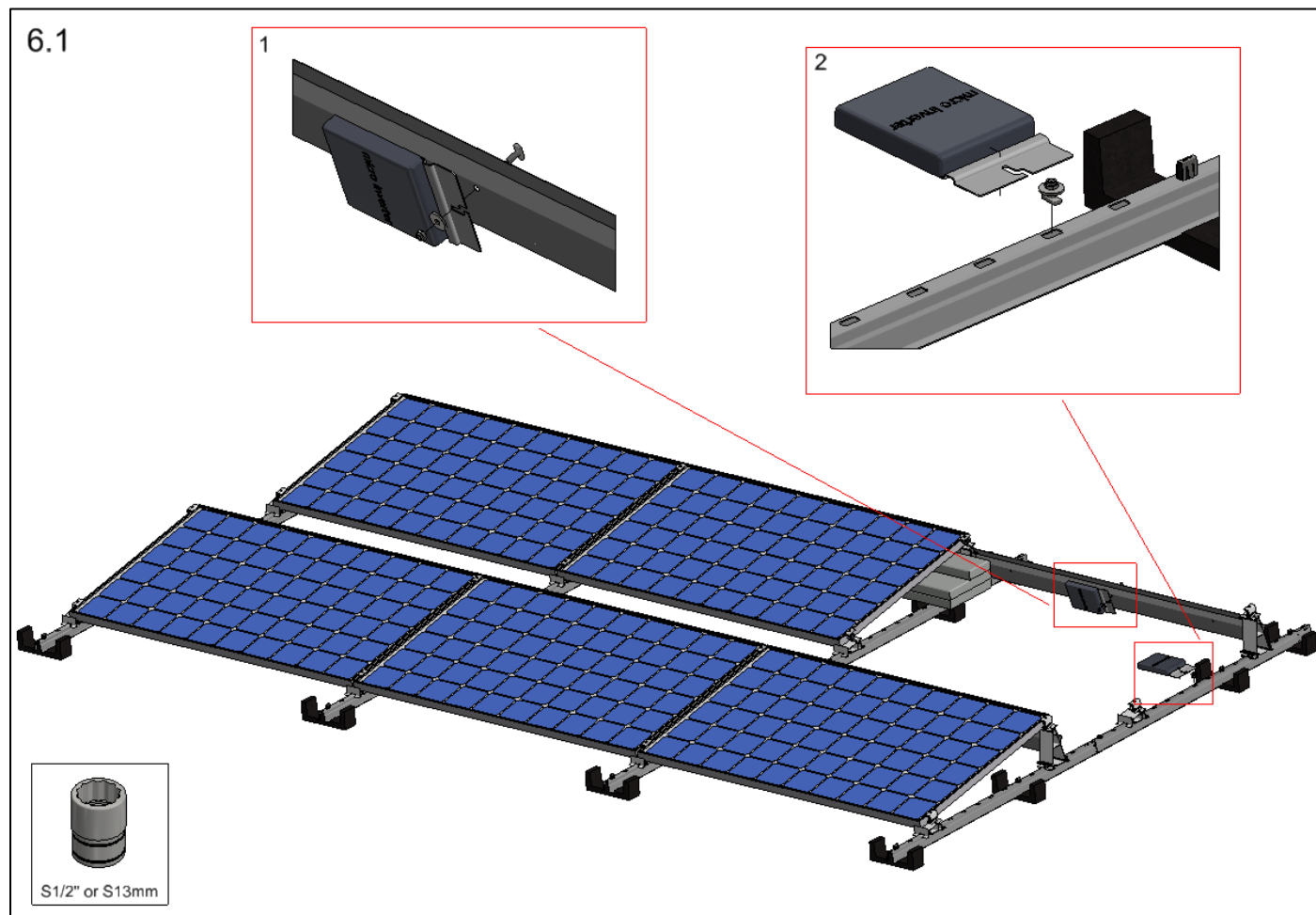

Dilatations

The ValkPro+ system has certain measurements that may not be exceeded due to thermal expansion/contraction. If these measurements are bigger than allowed, the system must be dilated. Once the system has a dilation, the system is now seen as 2 separate systems. If the dilations are not too big, some parts of the system can still be calculated as 'shielded panels'. (shielded panels have less ballast than the exposed panels)

Image 7.1 shows the system limitations and the preferred dimensions for the dilations.

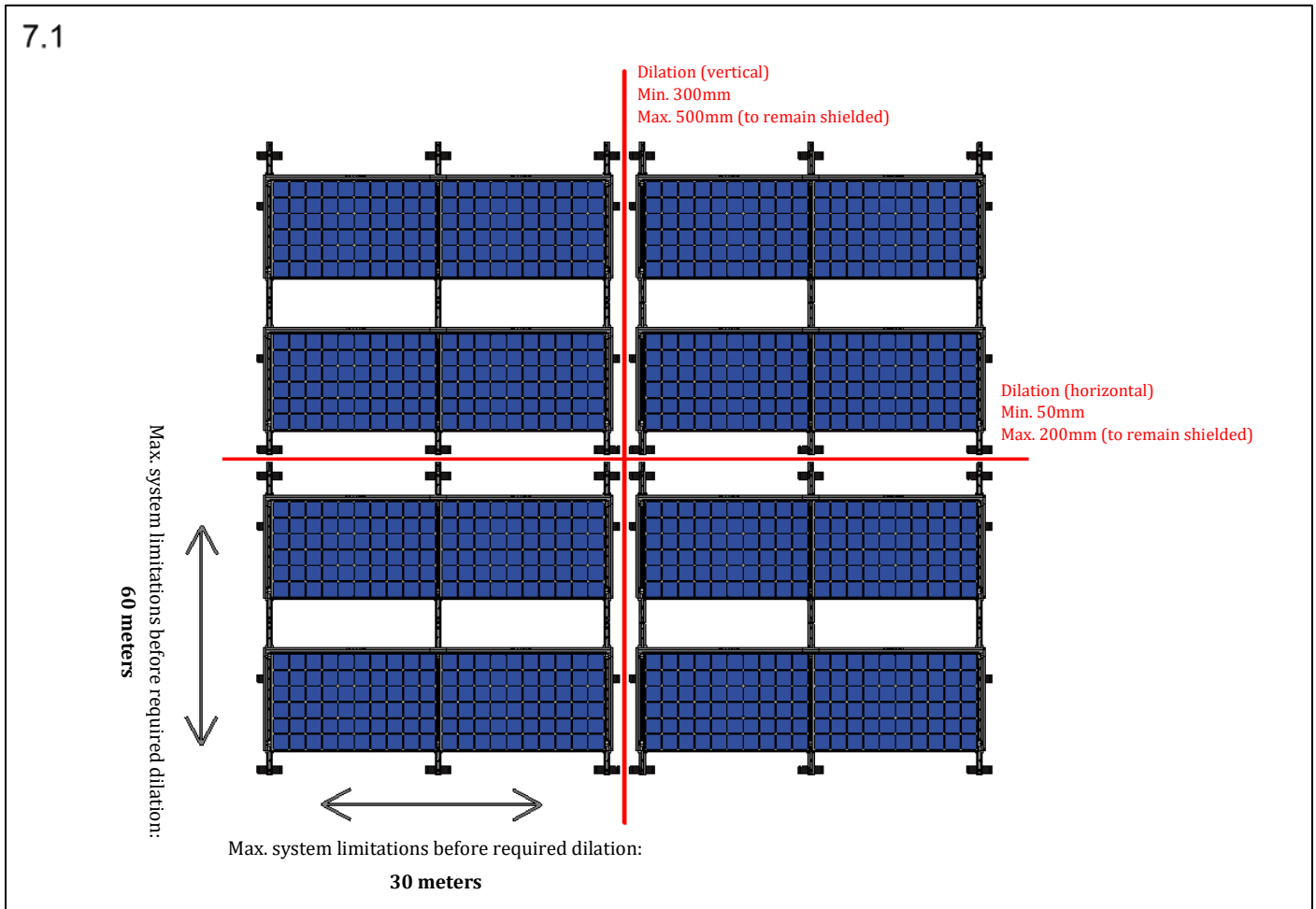

Cable management

On the ValkPro+ system there are a variety of ways to handle your cable management. The first feature is the cable clamps that are mounted on the aluminium back feet. The cable clamps are simply “clicked” on the aluminium feet, in these clamps the cables can be placed (see image 8.1)

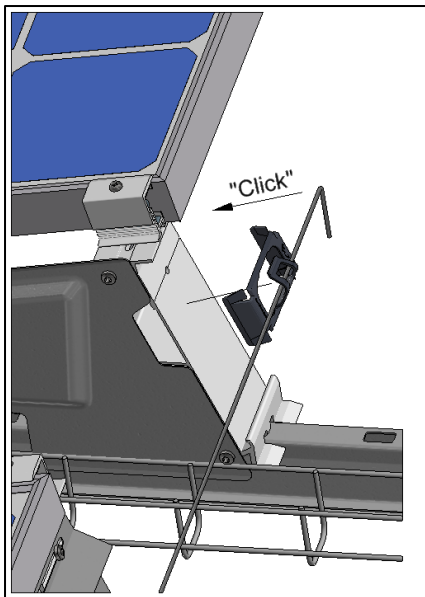

The cable clamp provides space for:

5 cables - Ø6mm

4 cables - Ø7mm

3 cables - Ø9mm

Most of the cables are placed in cable baskets. These cable baskets can easily be placed on the rubber tile carriers or the roof carriers. (see image 8.2, detail 1)

8.2

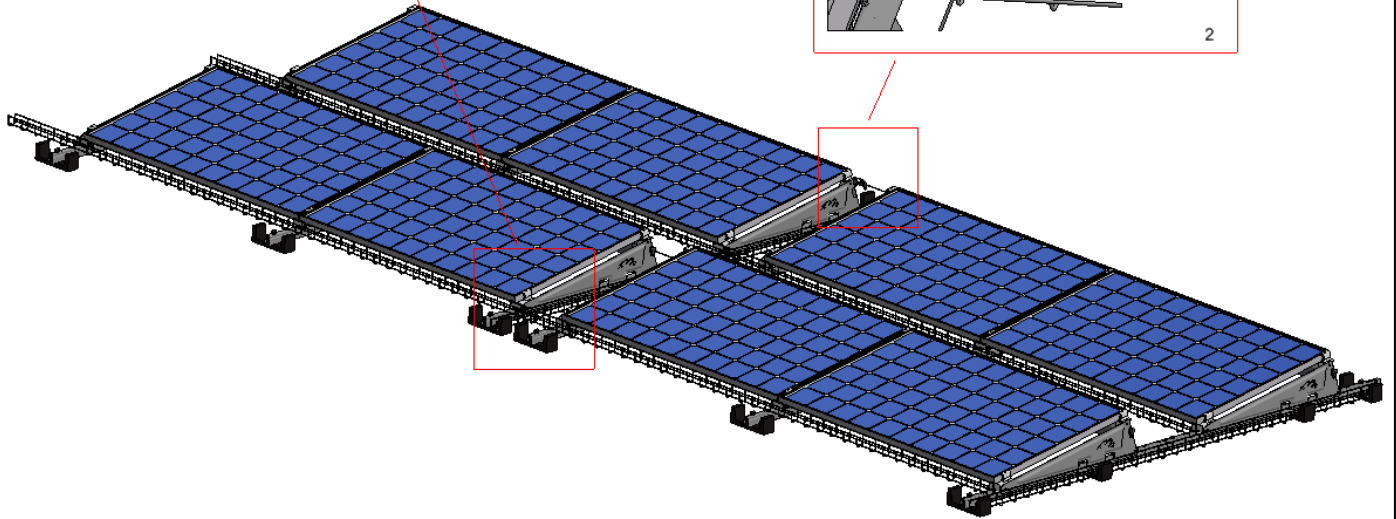
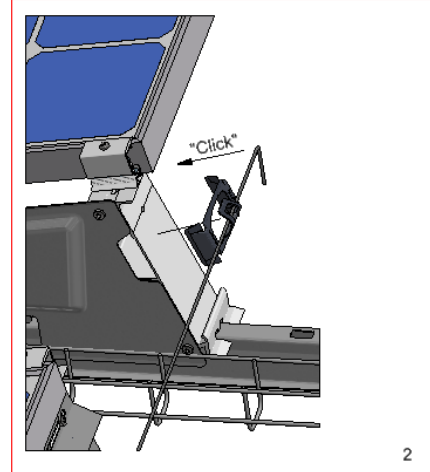
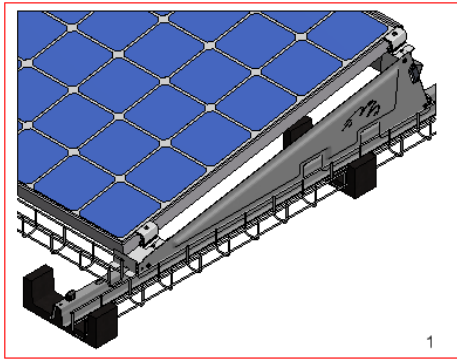

To cover the distance of a dilatation it is advised to use the dilatation wire (732020). This wire can be placed in the cable clamps and moves along with the thermal expansion/conduction. The cables can be fixed to the wire using tie-wraps, this keeps the cables free from the roof surface.

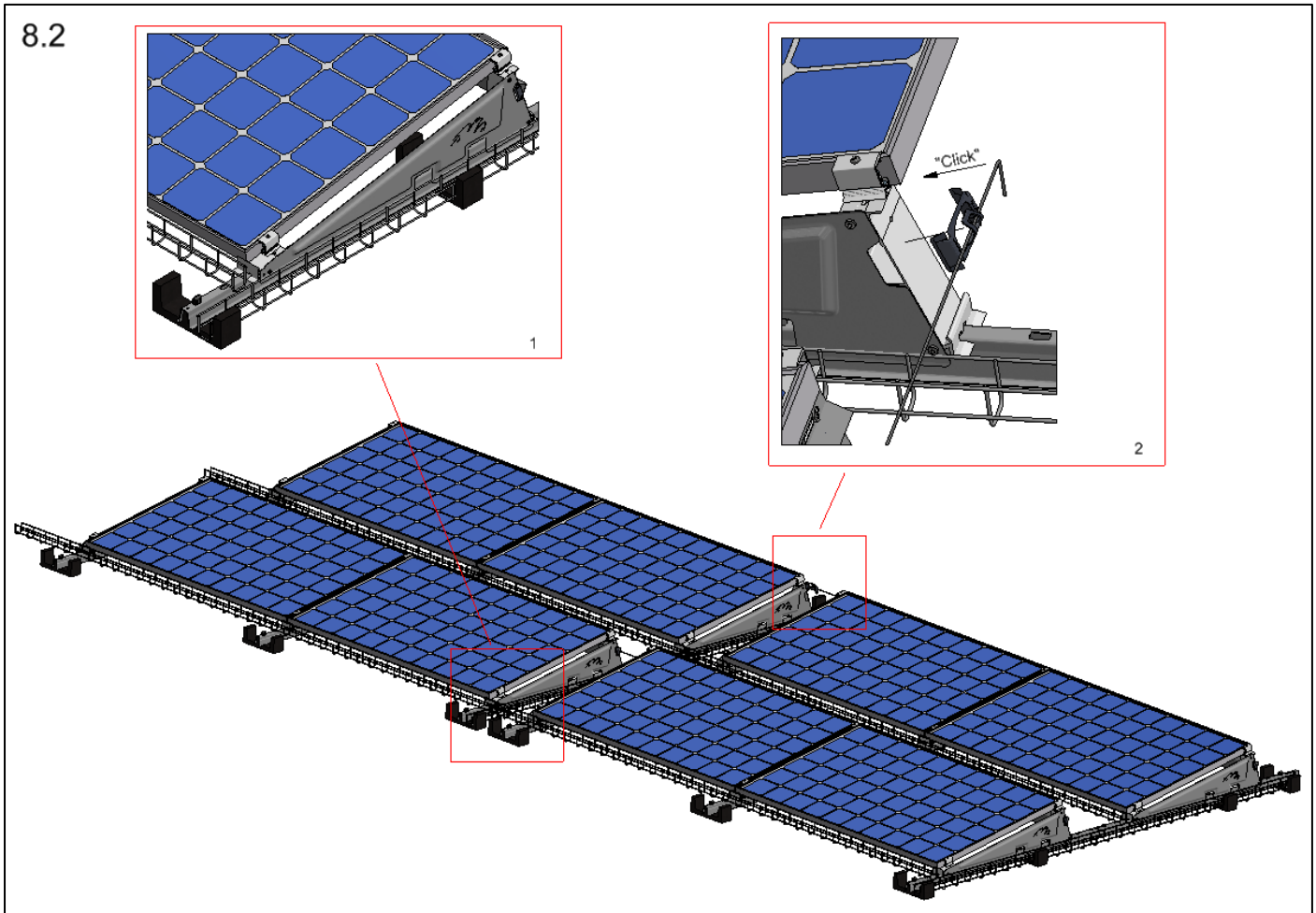

Specials

Beside a normal roof the ValkPro+ system can be placed on different surfaces. Each surface requires a different foundation method. Down below is shown what foundation method is used for each surface.

Gravel roofs:

If the roof is covered with gravel the system will be elevated with the rubber elevation blocks (729627). It is important that the distance between the gravel and the lowest part of the panel is between 115,5 – 95,5 mm.

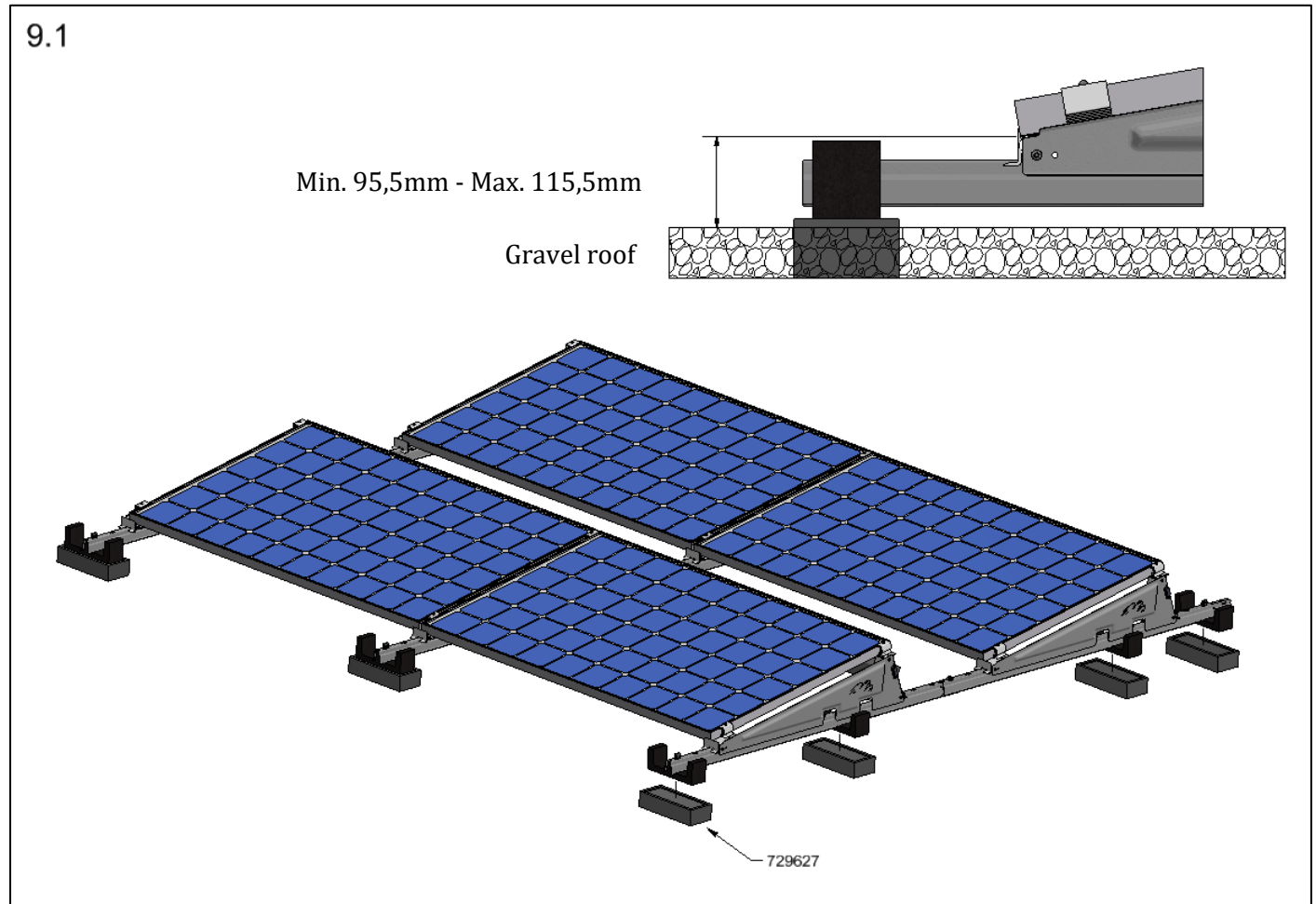

Sedum/green roofs:

If the system is placed on a sedum/green roof the system will be placed on the whole ballast tiles (7506303045). These tile provide a more suitable point load which prevent the system from lowering in the roof surface. It is important that the distance between the gravel and the lowest part of the panel is between 115,5 – 95,5 mm.

9.2

Min. 95,5mm - Max. 115,5mm

Sedum/green roof

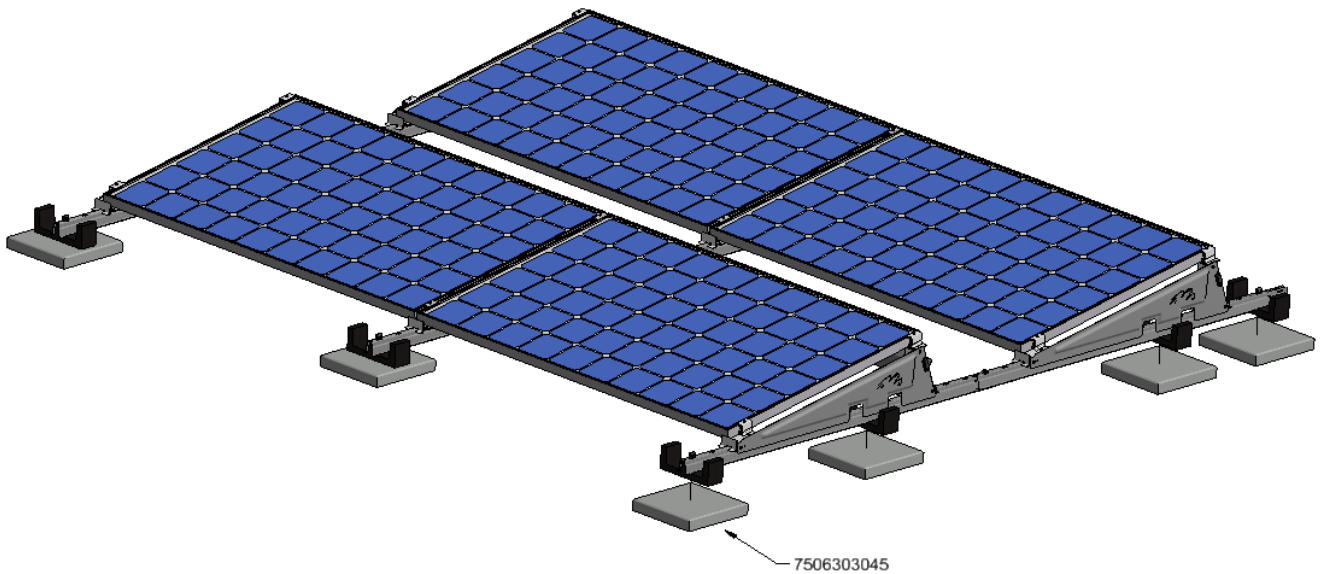
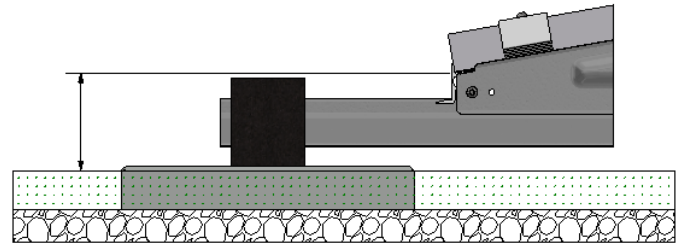

ValkPro+ as a field system:

The Valkpro+ system can be placed on the ground as a field system. For this method the system will be placed on top of the mass blocks (750520). These mass blocks are mounted to the roof carriers with a Ss. Ring and bolt (774009, 774065).

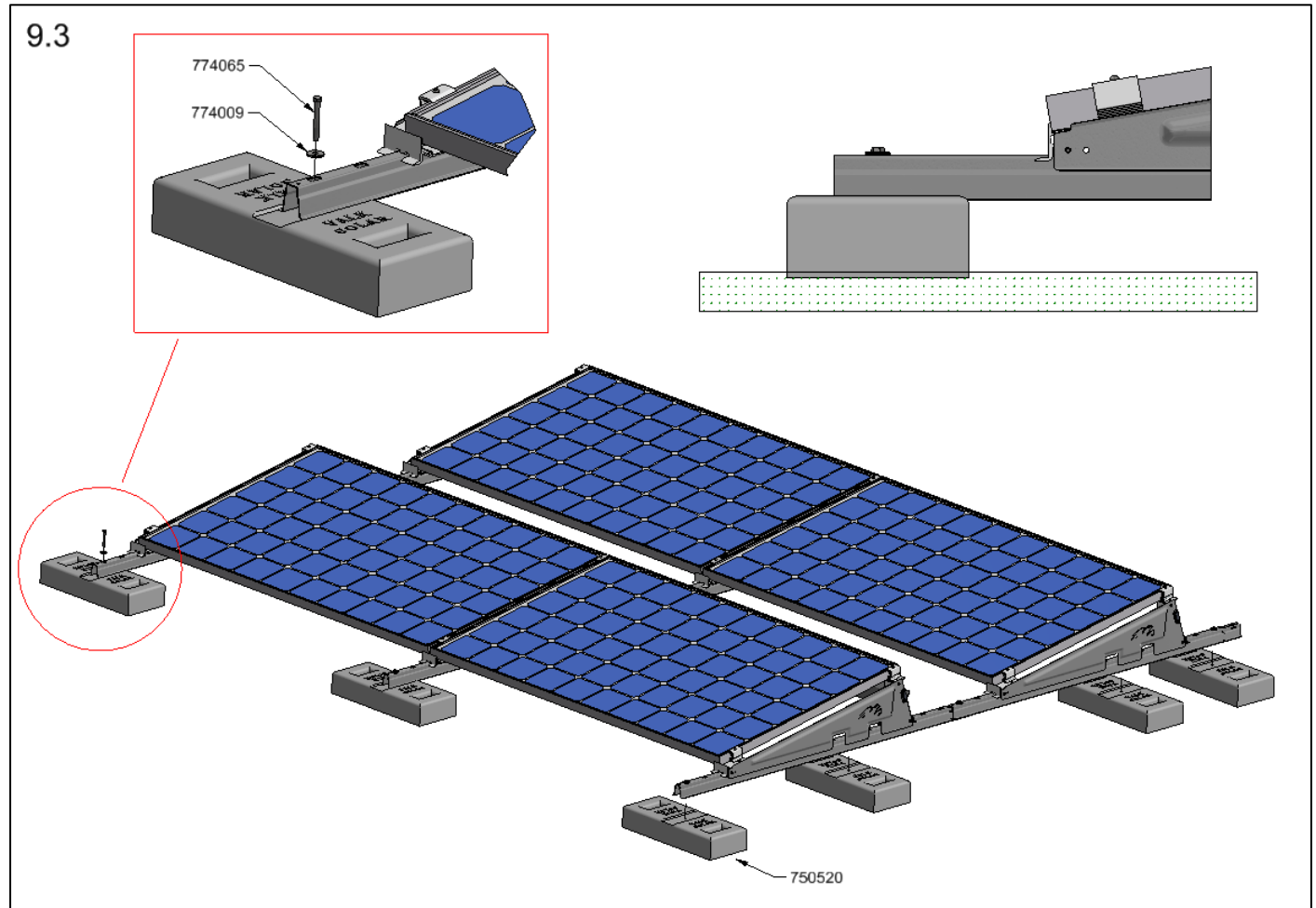

All ValkPro+ field systems are project specific. Please contact Van der Valk Solar Systems for a suitable solution.

Van der Valk Solar Systems

Van der Valk Solar Systems is one of the fastest growing companies in the solar industry. It concentrates solely on developing and manufacturing solar panel mounting systems for pitched roofs, flat roofs and open fields. Van der Valk Solar Systems also has an office and warehouse located in the UK.

Our mounting systems are developed and manufactured in our own factory in the Netherlands and are distinguished by their versatile application, very fast mounting and top quality. They comply with the latest Eurocodes and thus meet the requirements set by banks and insurance companies for solar systems. Van der Valk Solar Systems works closely together with Van der Valk Systemen, which since 1963 has upheld an international reputation in the field of mobile systems and fixation components.

Our joint industrial complex includes 20,000 m2 of offices and industrial buildings. By using modern machinery and the latest technology, products and systems can be developed, manufactured and tested quickly and precisely.



Why choose Van der Valk Solar Systems?

- Innovative systems developed in compliance with applicable worldwide standards
- Fast and reliable deliveries thanks to modern machinery and large stocks
- System supplier since 1963
- Free software for project design and project calculation
- All systems applicable to any type of roof or surface
- Quick assembly thanks to premounting of essential components
- All systems available in portrait as well as landscape configuration
- Various systems also available as ready-to-use kits

Developer and producer of solar mounting systems for:



Pitched roofs



Flat roofs



Open fields



Greenhouses



Water features

Zwartendijk 73, 2681 LP Monster
Nederland
T +31 (0)174 21 22 23
F +31 (0)174 24 27 27
Info@valksolarsystems.nl
www.valksolarsystems.nl

Innovation House, Discovery Park
Ramsgate Road, Sandwich CT13 9FF
United Kingdom
T +44 (0)1304 897658
Info@valksolarsystems.co.uk
www.valksolarsystems.co.uk

VAN DER VALK

