

# PLAYGROUND SPIELPLATZ

# GIOCO AIRE DE JEUX

(363 x 276 x h222cm)

003\_09700\_26052025

## BIBALU

INSTALLATION INSTRUCTIONS  
MONTAGEANLEITUNG

ISTRUZIONI DI MONTAGGIO  
GUIDE D'INSTALLATION

Warranty period - 2 years from purchase date

Garantiezeit - 2 Jahre ab Kaufdatum

Periodo di garanzia - 2 anni dalla data di acquisto

Période de garantie - 2 ans à compter de l'achat

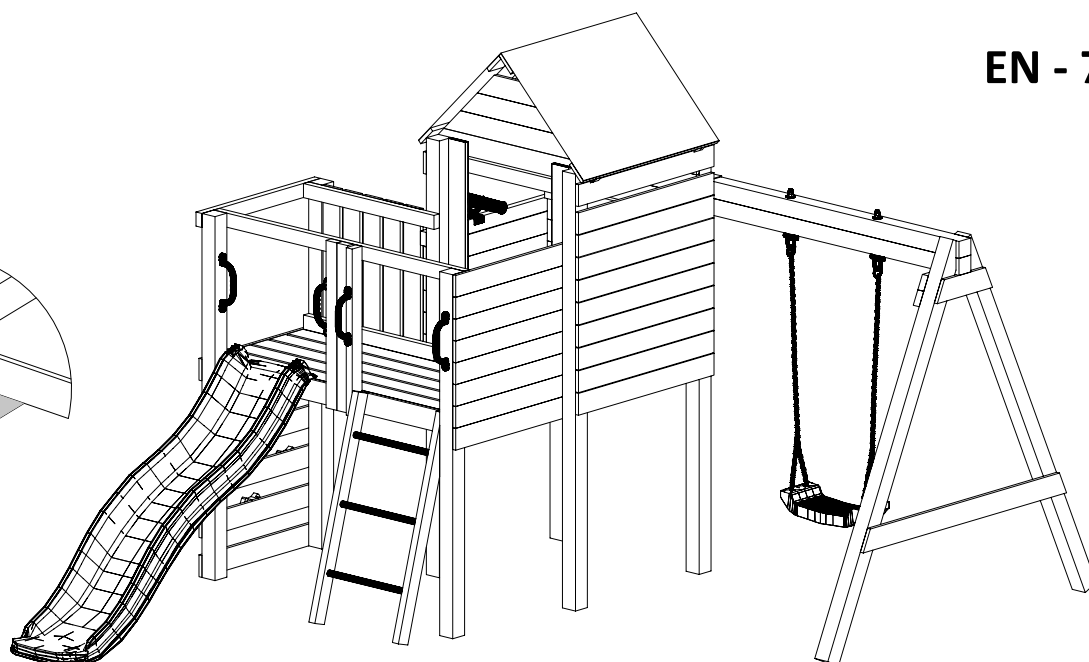
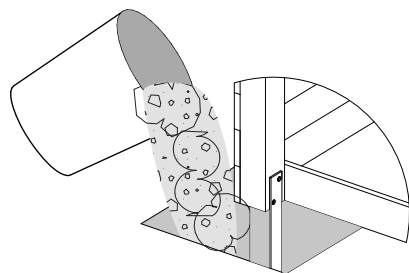

EN - 71

### WARNINGS!

Only for home use.

Dedicated for external use only.

Not suitable for children under 3 years old.

Risk of falling down and/or hitting.

Maximum user weight is up to 50 kg.

Maximum number of users staying on the  
playground at the same time: 7.

### ATTENZIONE!

Solo per uso domestico.

Articolo per uso esterno.

Previsto per bambini di età superiore ai 3 anni.

Pericolo di caduta, e/o impatto.

Peso massimo di utente : 50kg

Numero massimo di utilizzatori  
del gioco nello stesso momento: 7.

### ACHTUNG!

Nur für den privaten, häuslichen Bereich.

Ausschließlich für die Verwendung im Freien.

Nicht geeignet für Kinder unter 3 Jahren.

Stolper- und / oder Sturzgefahr

Höchstgewicht pro Einzelkind beträgt 50 kg

Der Aufenthalt auf diesem Spielturm ist max. : 7.  
Kindern gleichzeitig erlaubt.

### AVERTISSEMENT!

Aire exclusivement destinée à un usage privé.

Aire exclusivement destinée à un usage en extérieur.

Prévue pour les enfants de plus de 3 ans.

Danger de chute ou de choc.

Poids maximal d'un utilisateur : 50 kg.

Nombre maximal d'utilisateurs présents en  
même temps sur la même aire de jeux: 7.

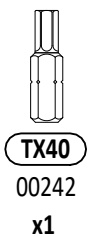
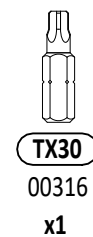
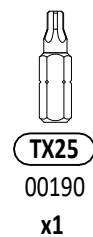
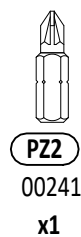
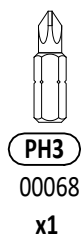
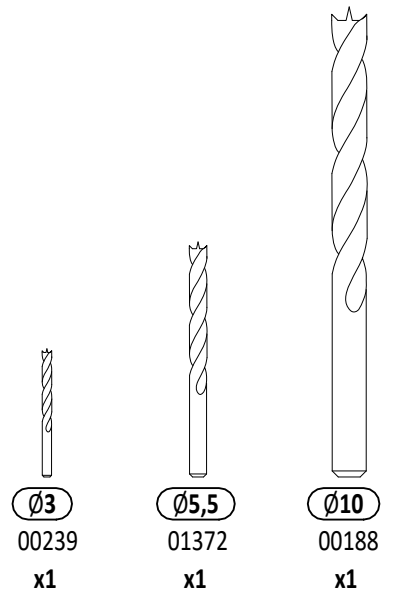
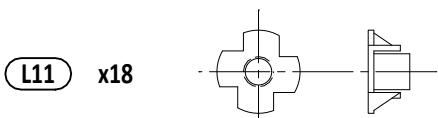
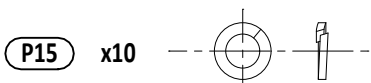
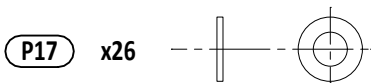
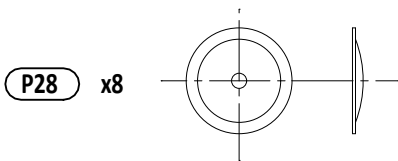
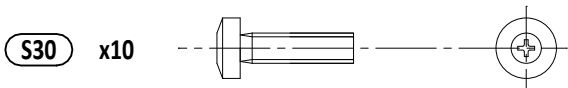
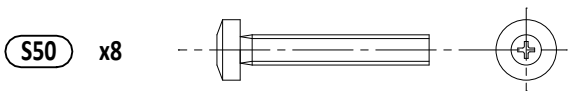
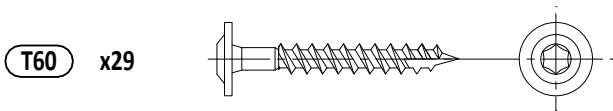
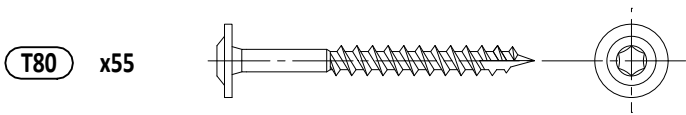
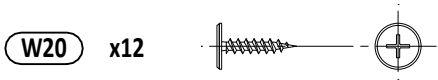
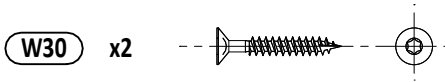
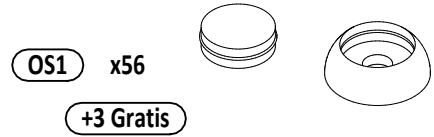
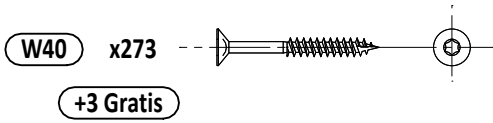
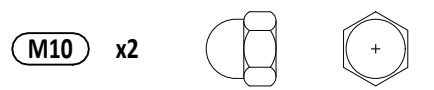
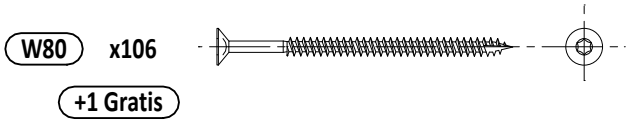

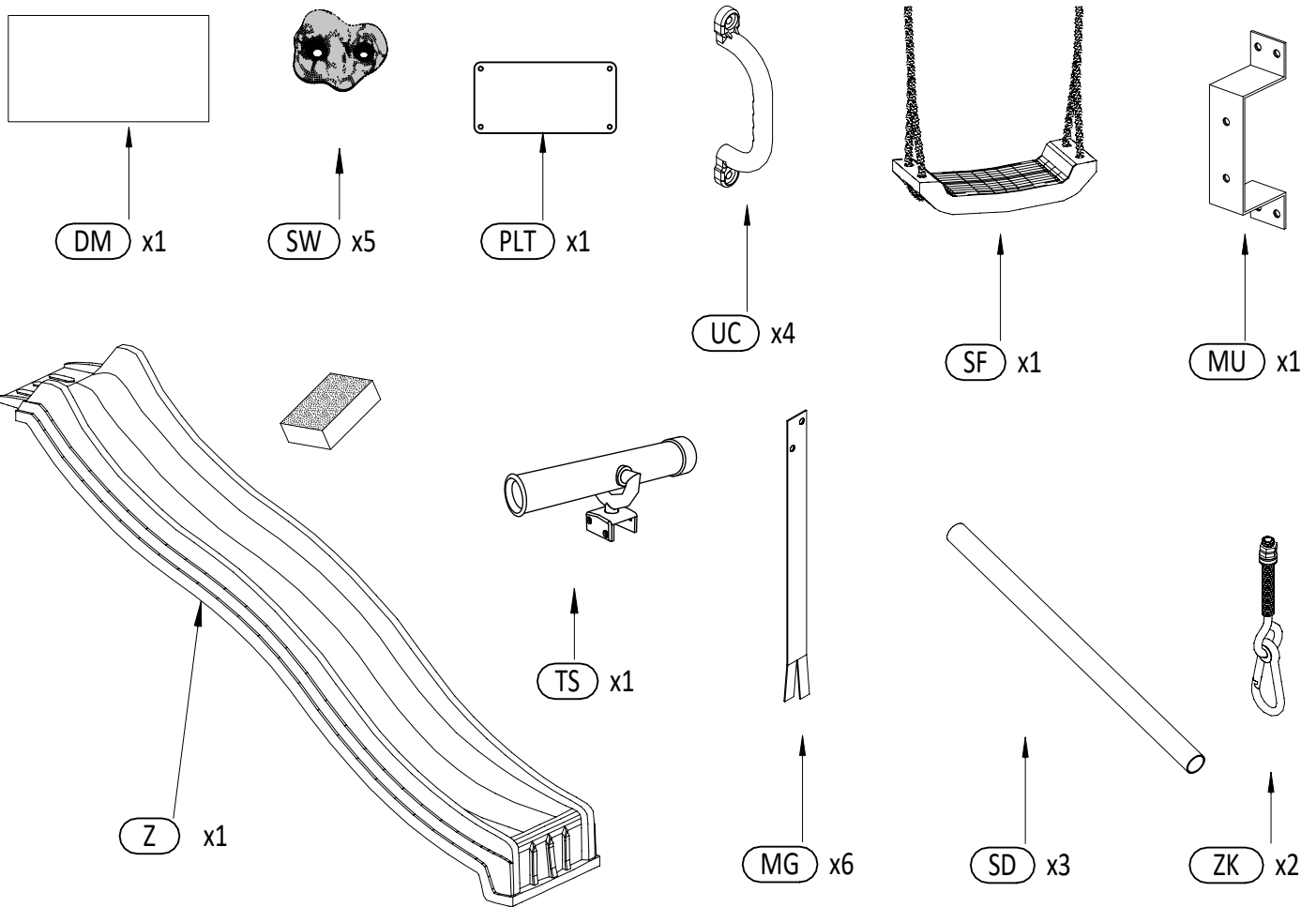
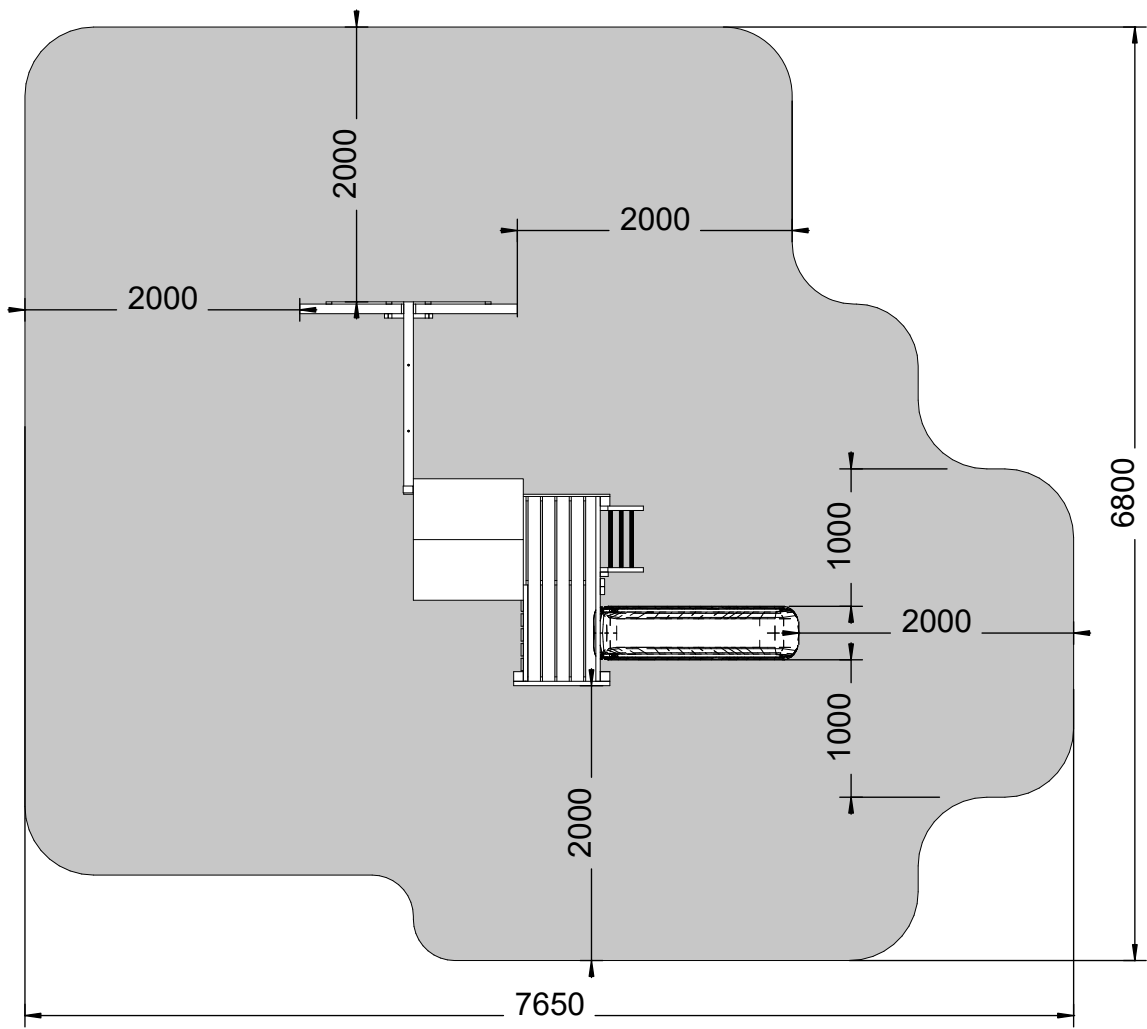

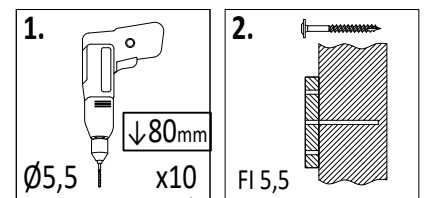
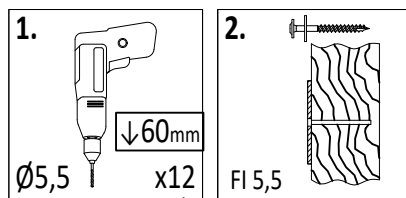
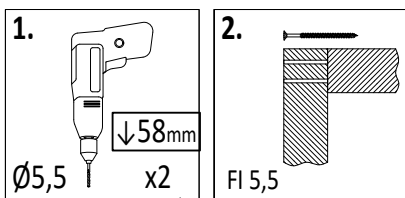
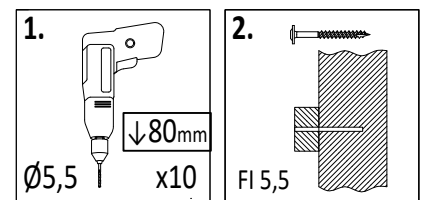
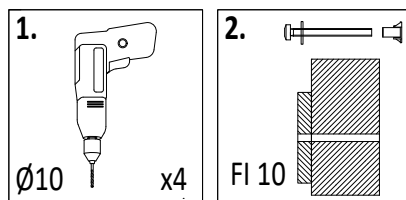
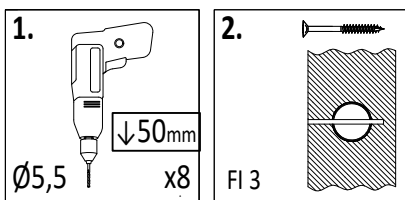
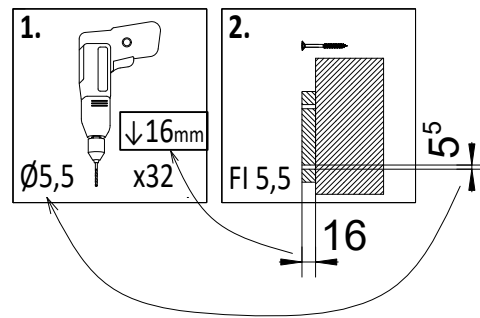
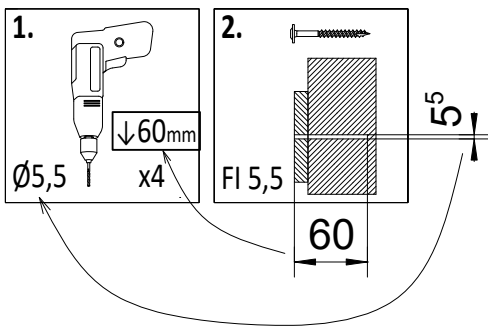
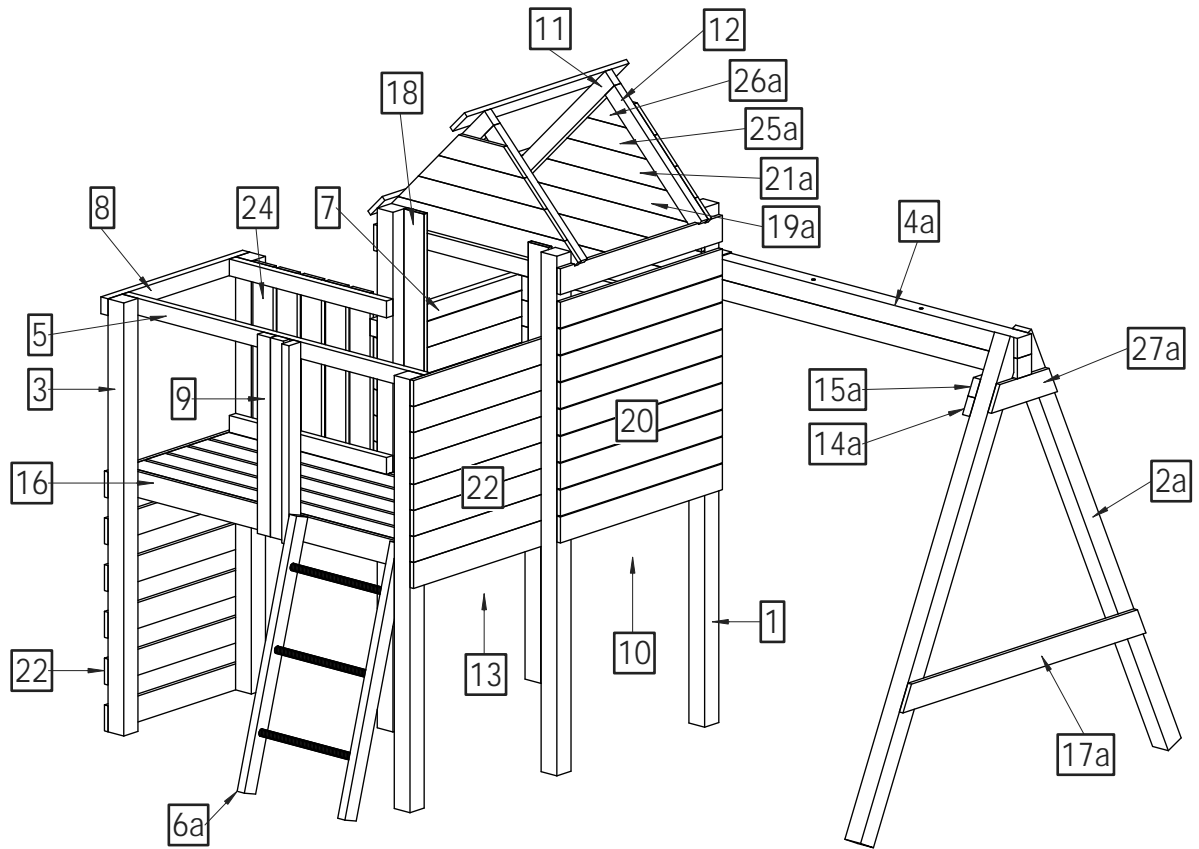

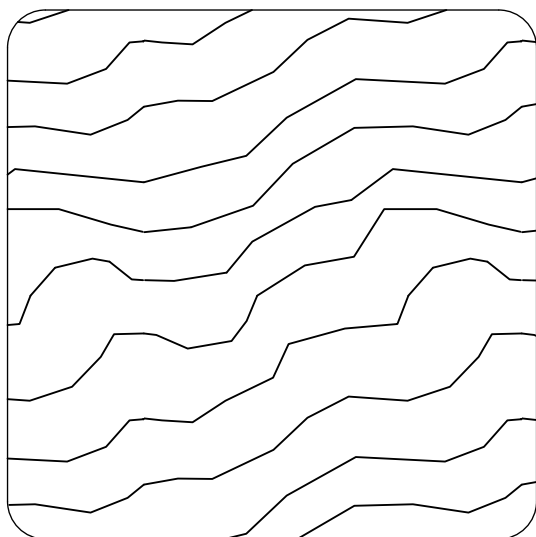

**7,0 x 7,0 cm**

Lp.	Kod	Wymiary [mm]	szt.
1	05245	70x70x1800mm	4
2a	05305	70x70x1750mm	2
3	08538	70x70x1500mm	3
4a	05307	70x70x1400mm	2

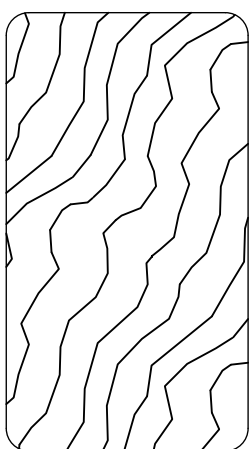

**3,2 x 5,8 cm**

Lp.	Kod	Wymiary [mm]	szt.
5	09641	32x58x1345mm	1
6a	05273	32x58x940mm	2
7	04457	32x58x800mm	5
8	05219	32x58x700mm	3
9	04615	32x58x690mm	3
10	04459	32x58x628mm	3
11	04617	32x58x610mm	4
12	04619	32x58x550mm	2
13	05221	32x58x528mm	1
14a	04461	32x58x350mm	1
15a	04463	32x58x296mm	1



**1,6 x 9,0 cm**

Lp.	Kod	Wymiary [mm]	szt.
16	09675	16x90x1345mm	6
17a	03920	16x90x1200mm	1
18	05181	16x90x900mm	2
19a	04643	16x90x860mm	2
20	04465	16x90x800mm	37
21a	04546	16x90x740mm	2
22	05223	16x90x700mm	15
23	09685	16x90x644mm	1
24	04625	16x90x600mm	5
25a	04467	16x90x560mm	2
26a	04548	16x90x380mm	2
27a	04469	16x90x325mm	1

1

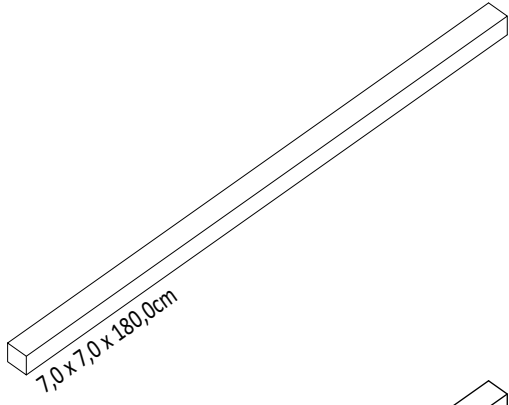

5

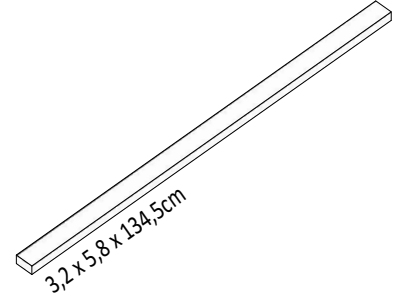

2a

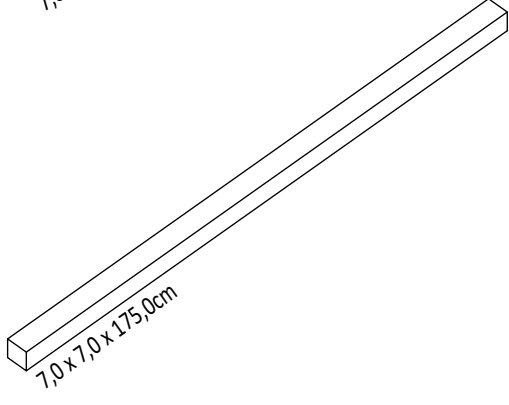

6a

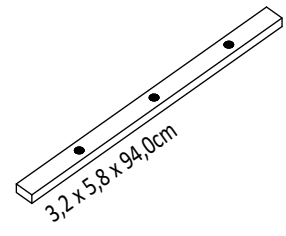

3

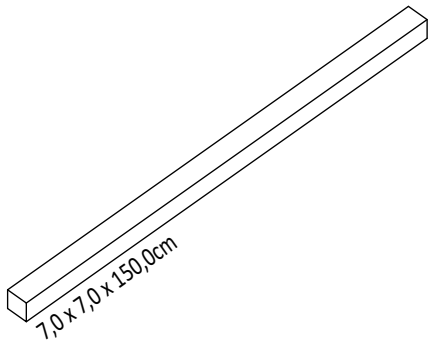

7

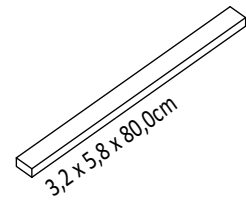

4a

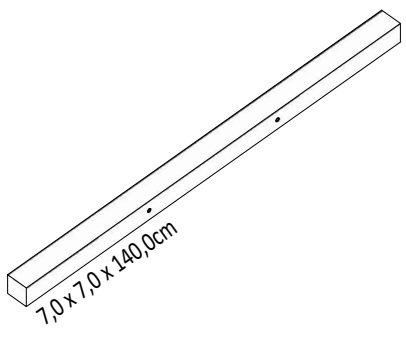

8

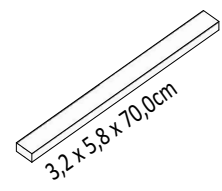

9

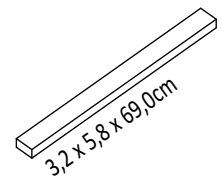

10

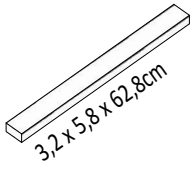

16

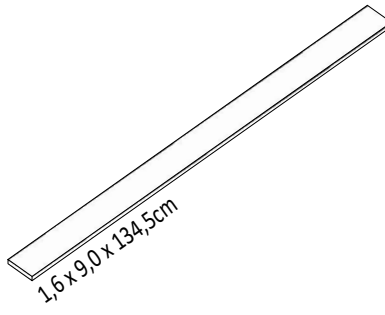

22

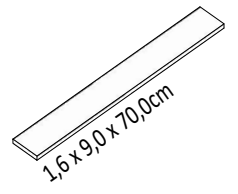

11

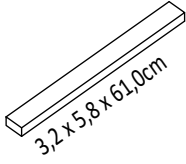

17a

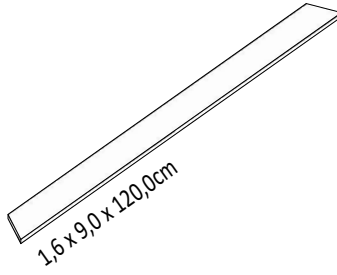

23

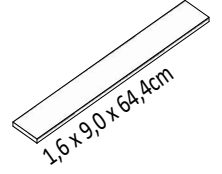

12

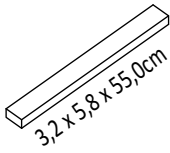

18

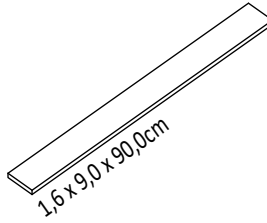

24

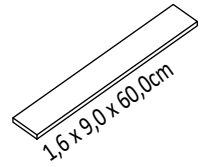

13

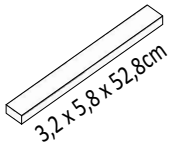

19a

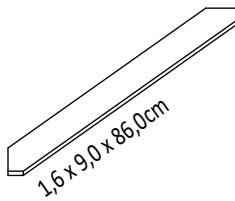

25a

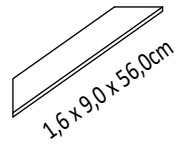

14a

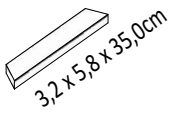

20

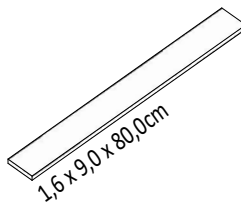

26a

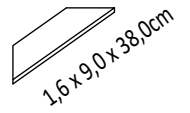

15a

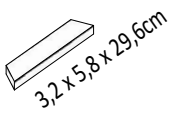

21a

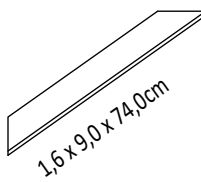

27a

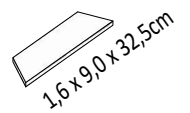

01

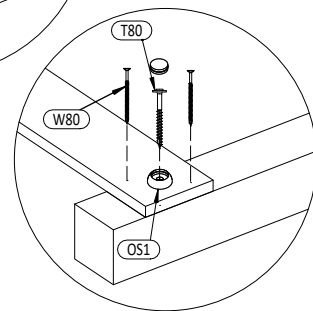
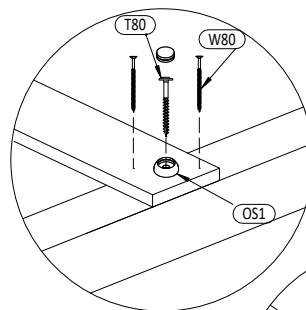
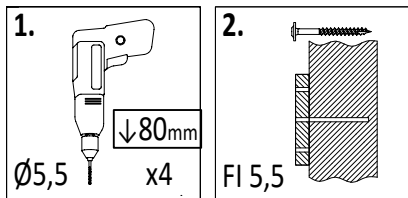

!!! x2

20 1,6x9,0x80cm x2

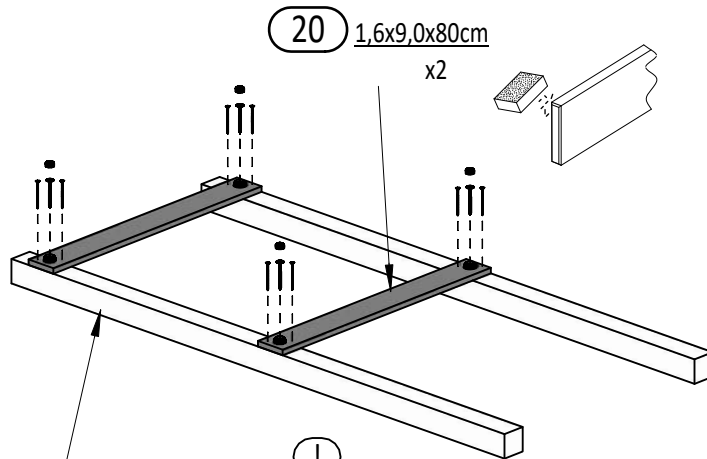

!



OS1 x4 \*2 = 8

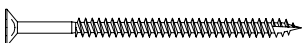

W80 x12 \*2 = 24

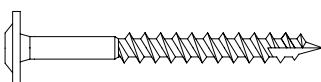

T80 x4 \*2 = 8

1 7,0x7,0x180cm x2

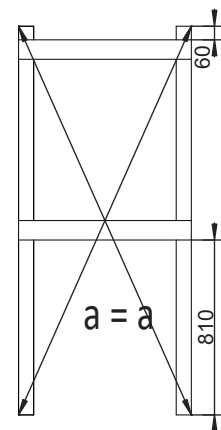

02

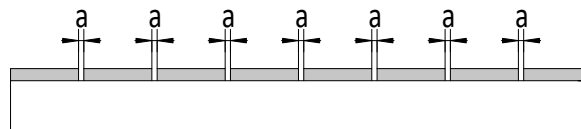
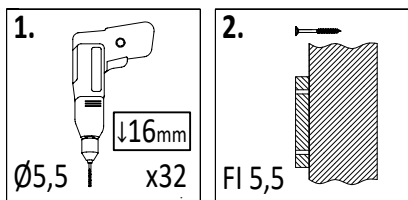

!!!min 2mm < a < !!!max 6mm

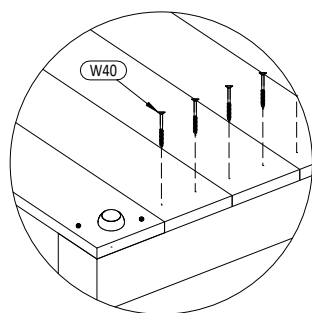

!!! x1

20 1,6x9,0x80cm x8

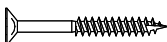
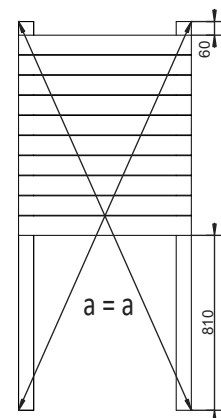
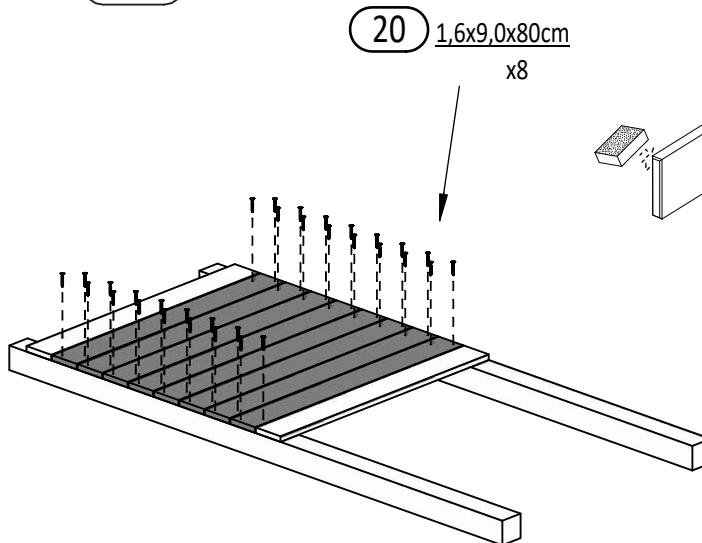

W40 x32

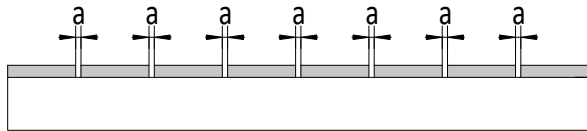

!!!min 2mm < a < !!!max 6mm

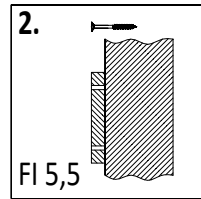
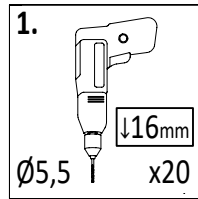
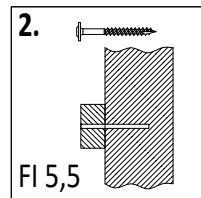
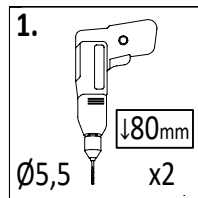
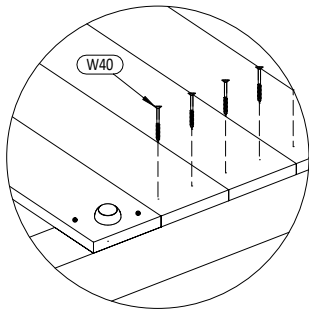
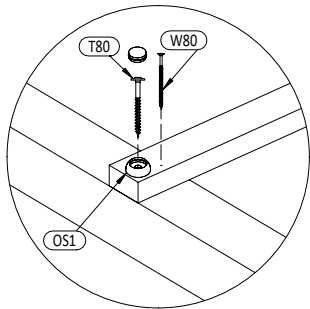

7 3,2x5,8x80cm x1

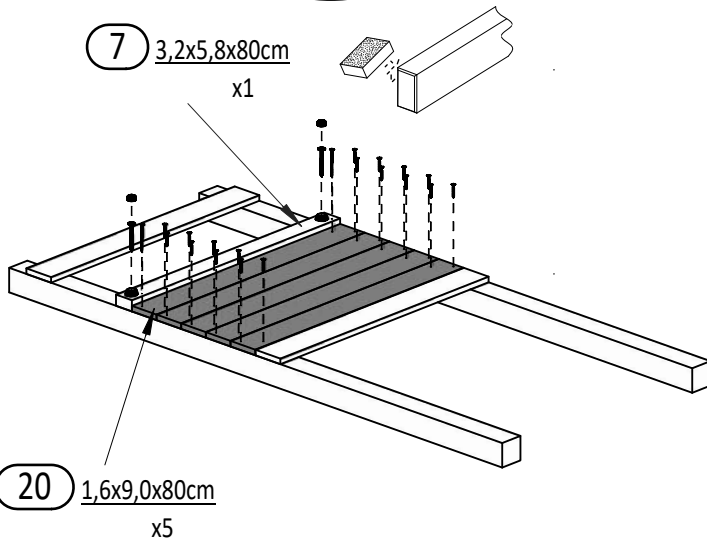
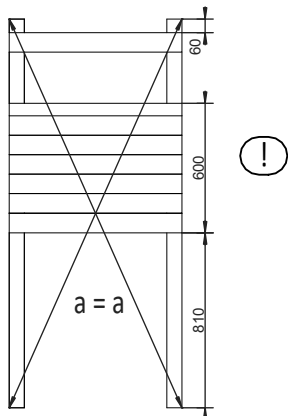

20 1,6x9,0x80cm x5

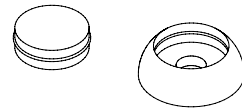

OS1 x2

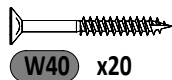

W40 x20

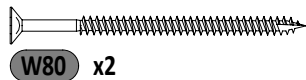

W80 x2



T80 x2

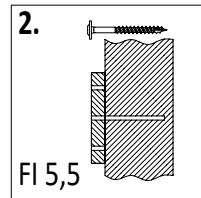
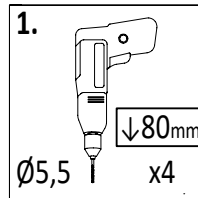
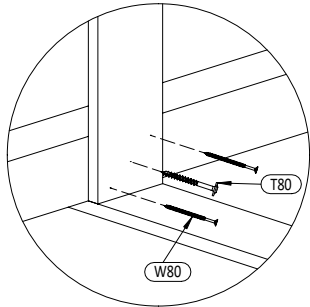

7 3,2x5,8x80cm x1

20 1,6x9,0x80cm x3

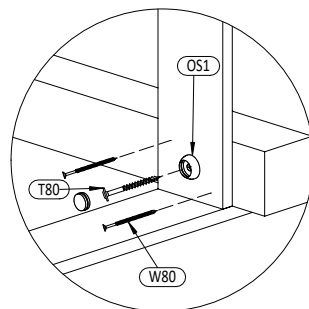
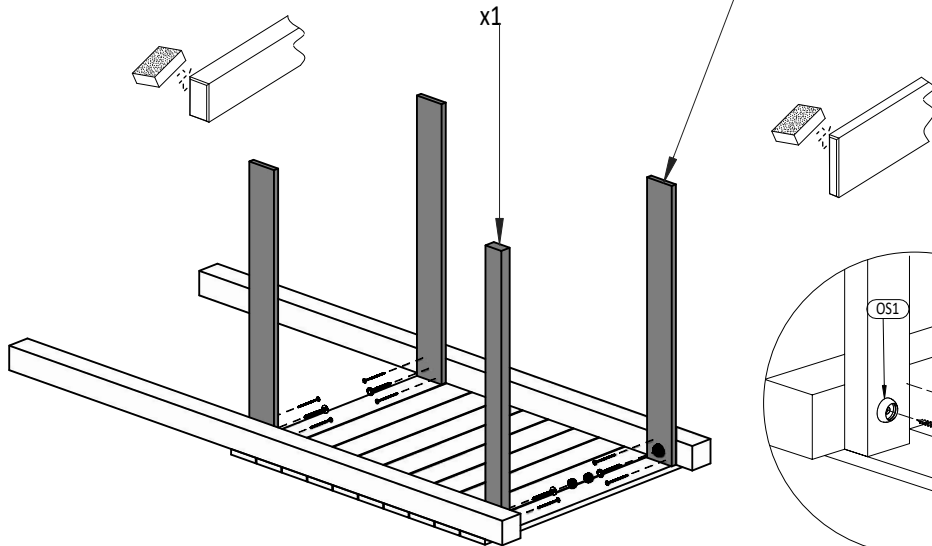

OS1 x2

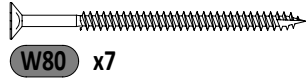

W80 x7

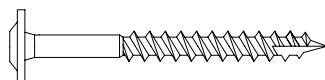

T80 x4

05

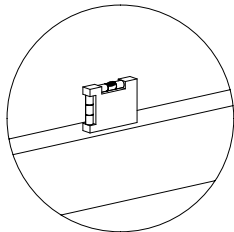
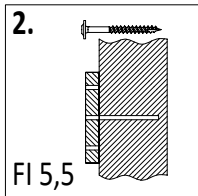
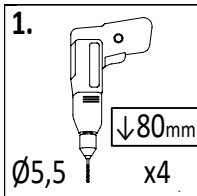

OS1 x2

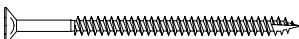

W80 x7



T80 x4

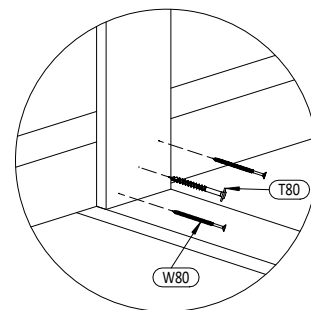
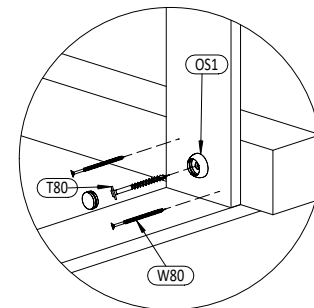
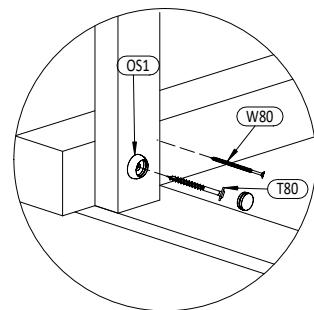
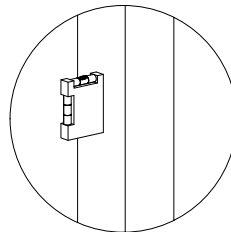
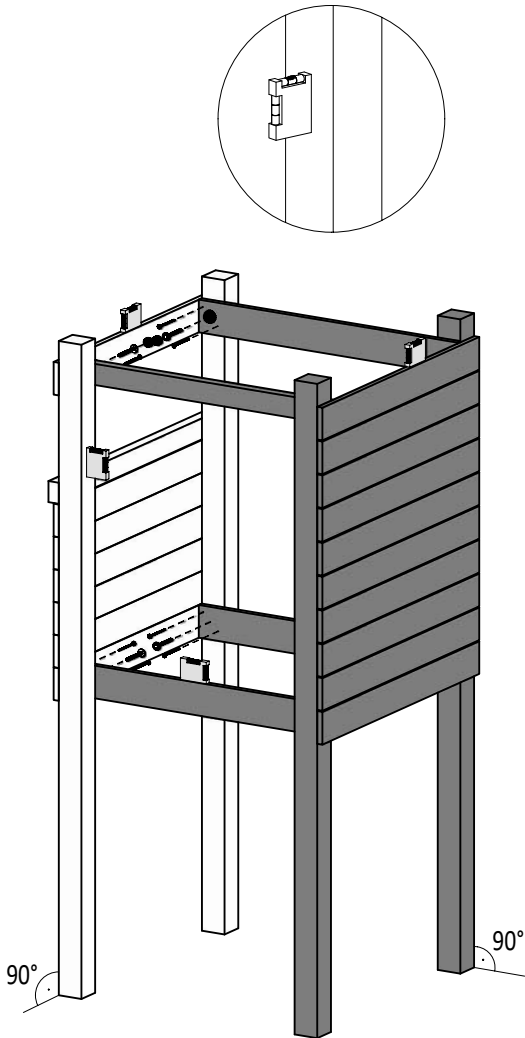

06

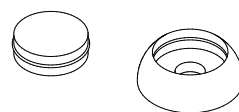
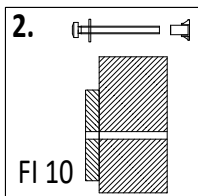
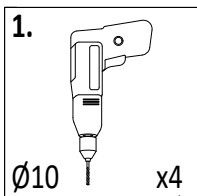

OS1 x4

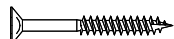

W40 x6

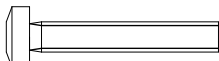

S50 x4



P17 x4



L11 x4

10 3,2x5,8x62,8cm  
 x2

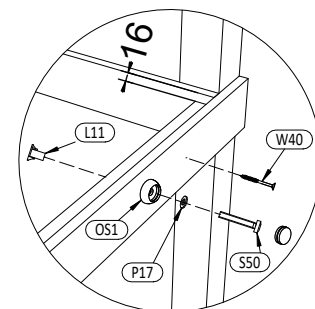
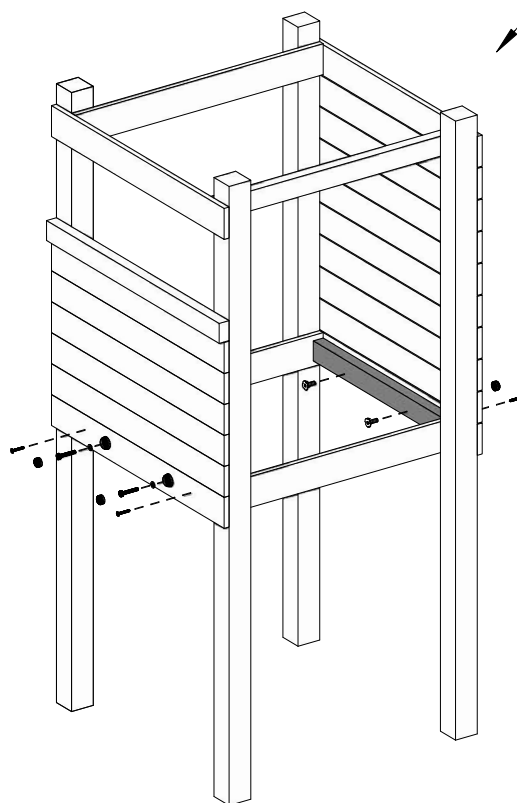

10 3,2x5,8x62,8cm  
x1

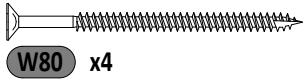
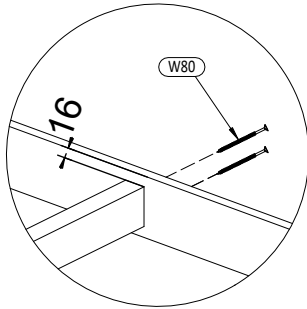
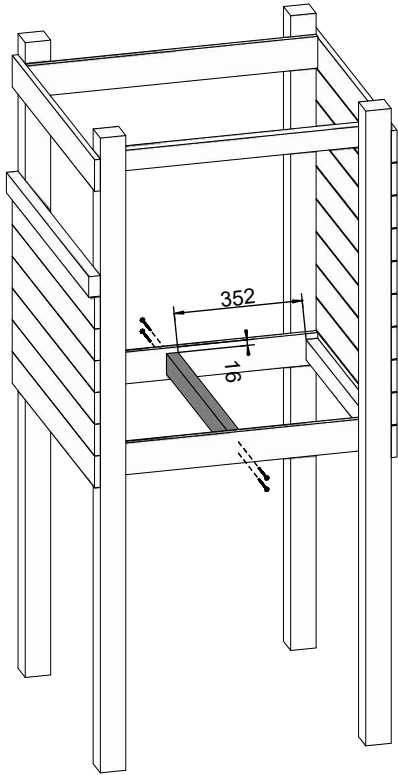

20 1,6x9,0x80cm  
x6

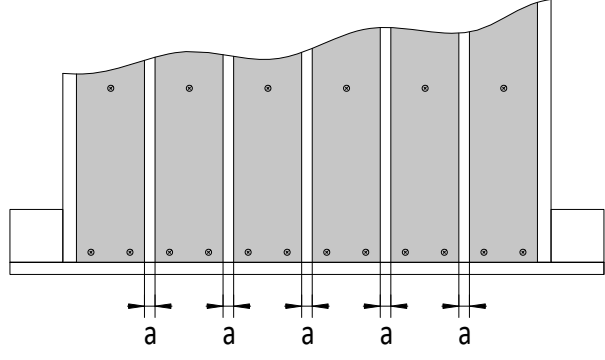
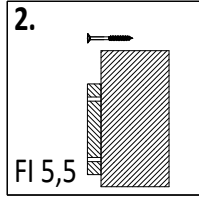
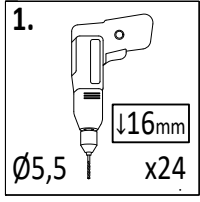
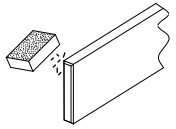
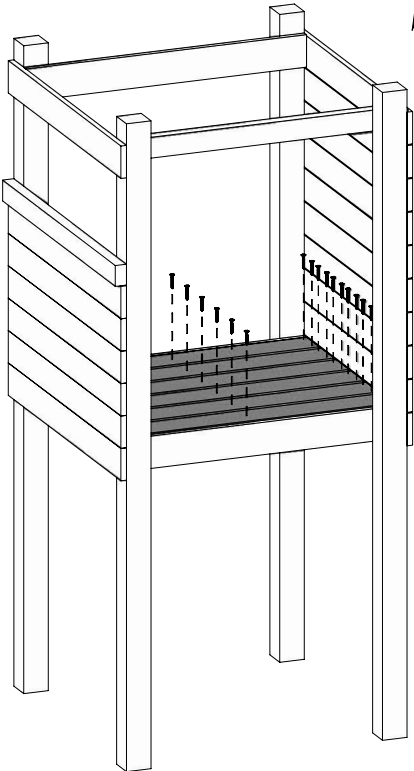

!!!min 13mm < a < !!!max 16mm

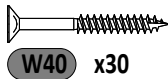

Zgodnie z normą PN-EN 71 stosuj zalecenia producenta odnośnie odległości oraz metody mocowania poszczególnych elementów  
In compliance with the standard PN-EN 71, apply guidelines of the producer in relation to distances and methods of fastening individual elements

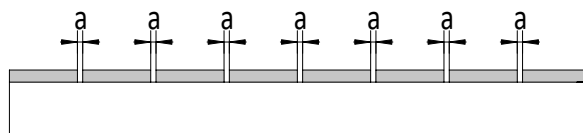
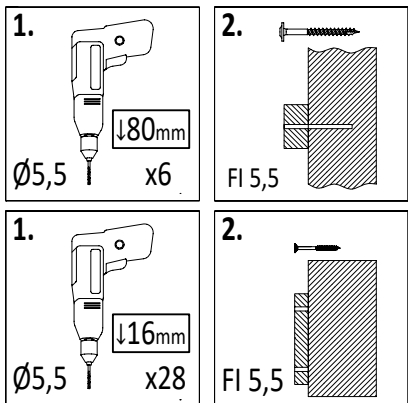

!!!min 2mm < a < !!!max 6mm

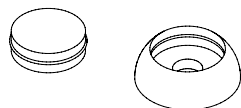
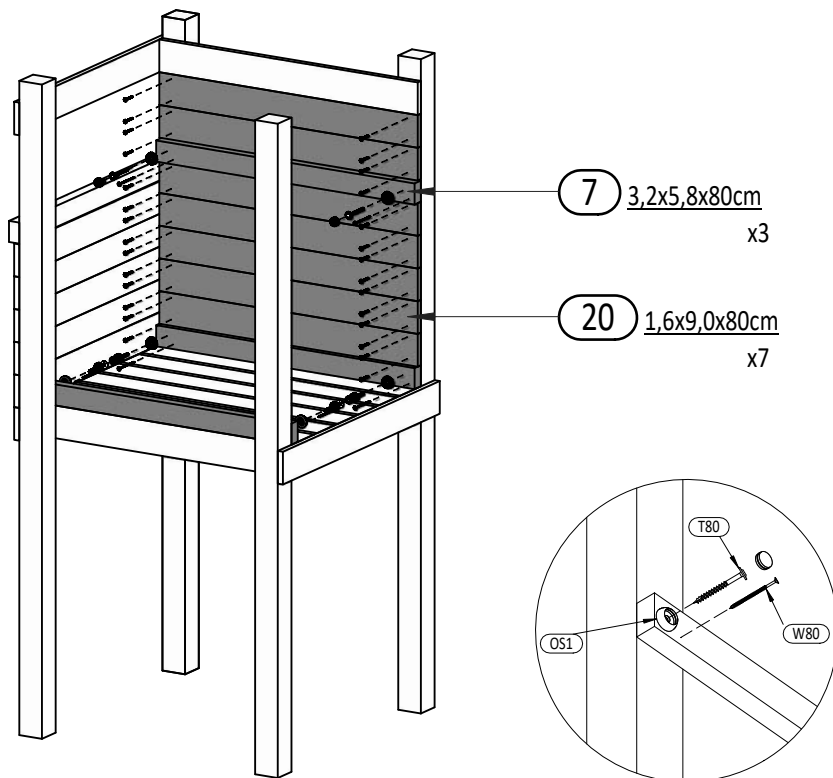

OS1 x6



W40 x28



W80 x6

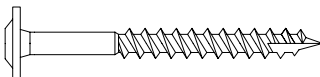

T80 x6

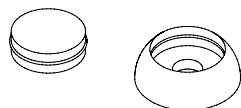
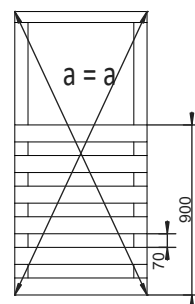
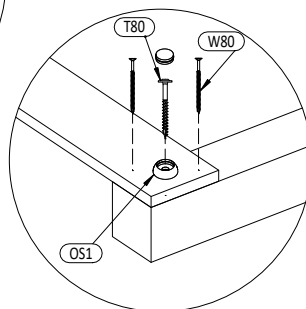
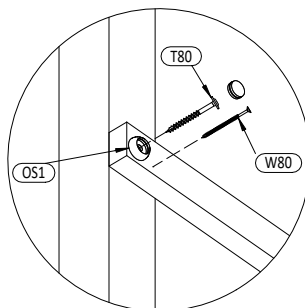
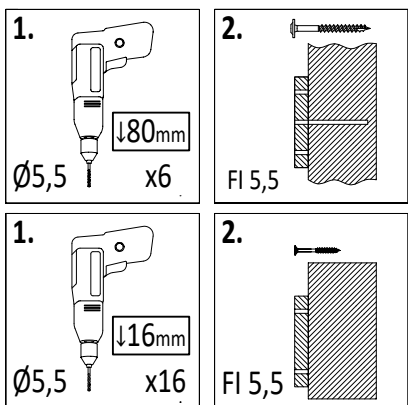

OS1 x6

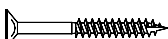

W40 x16



W80 x10



T80 x6

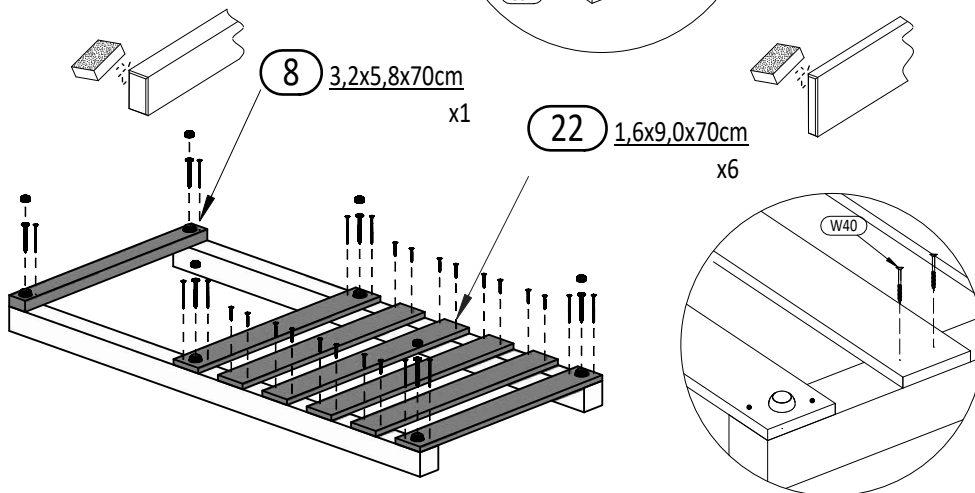

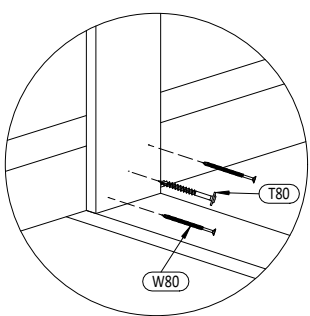
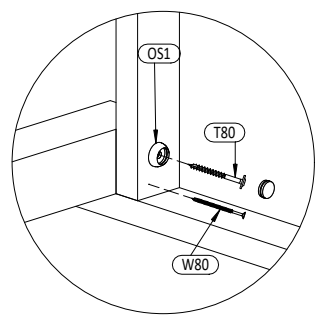
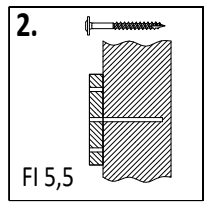
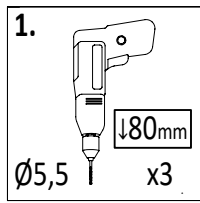
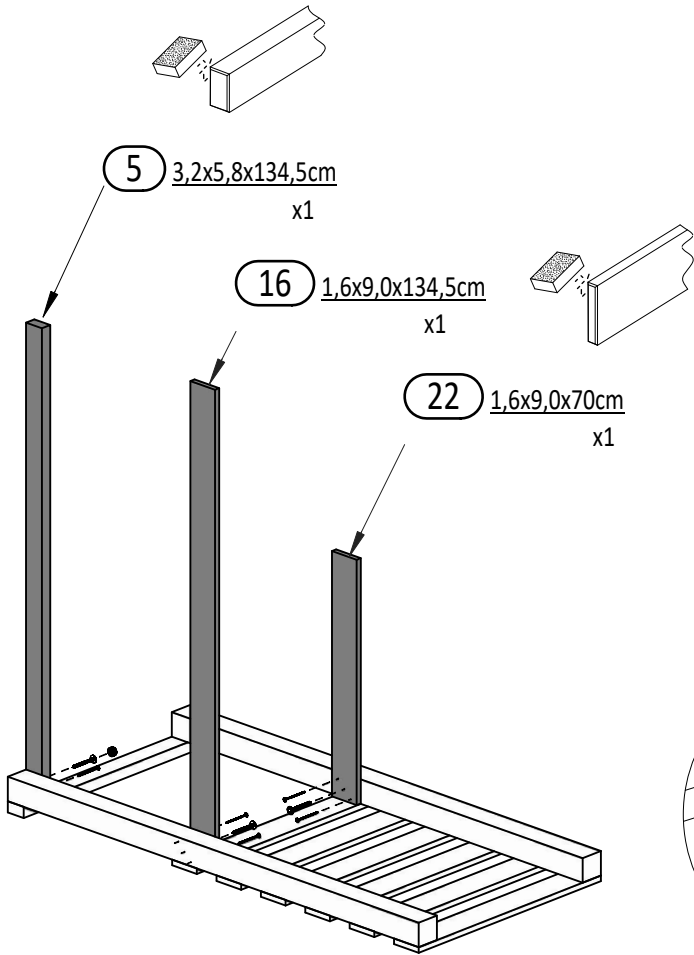

- OS1 x1
- W80 x5
- T80 x3

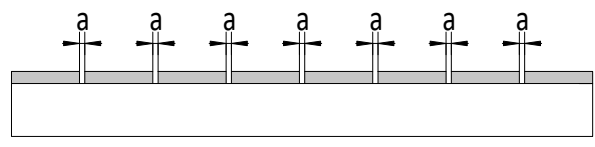
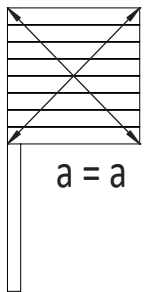

!!!min 2mm < a < !!!max 6mm

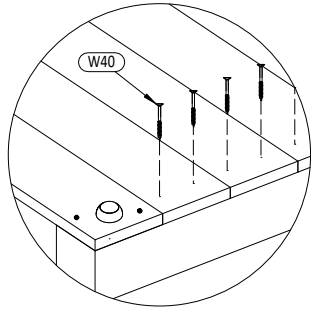
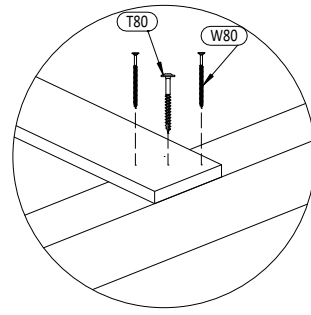
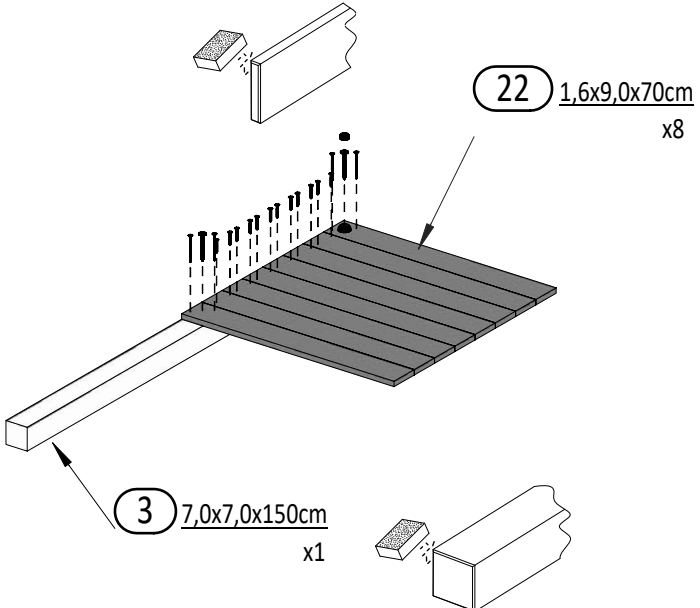
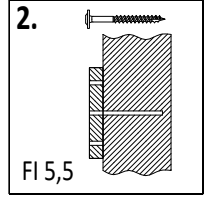
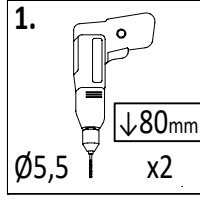

- OS1 x1
- W40 x12
- W80 x4
- T80 x2

Zgodnie z normą PN-EN 71 stosuj zalecenia producenta odnośnie odległości oraz metody mocowania poszczególnych elementów  
 In compliance with the standard PN-EN 71, apply guidelines of the producer in relation to distances and methods of fastening individual elements

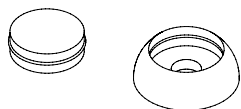
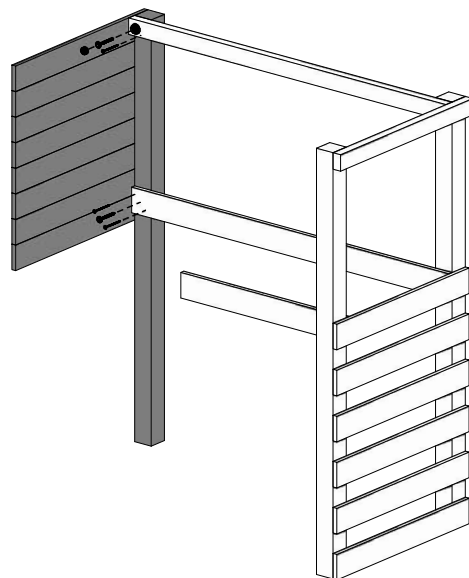
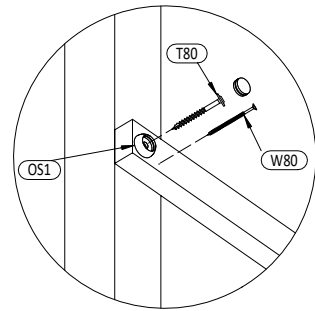
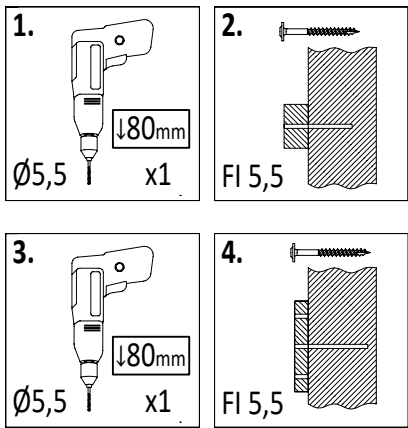

OS1 x1

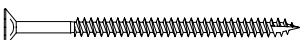

W80 x3



T80 x2

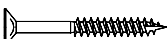
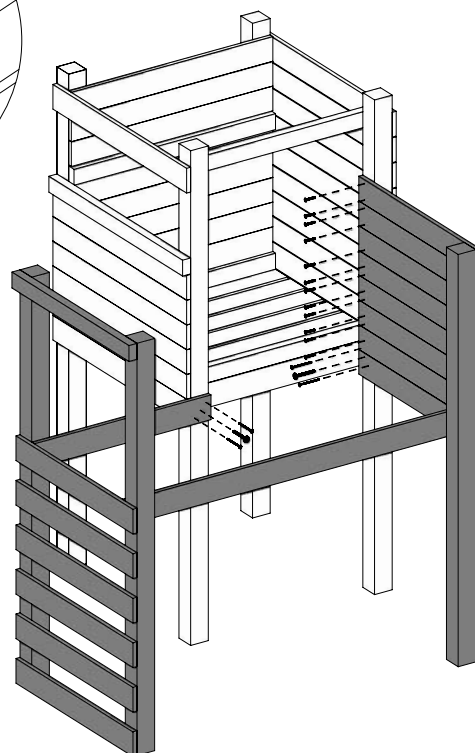
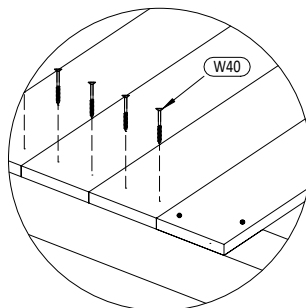
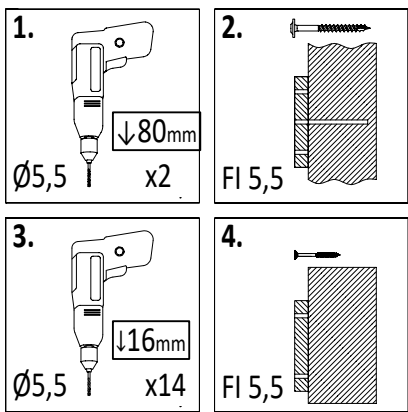
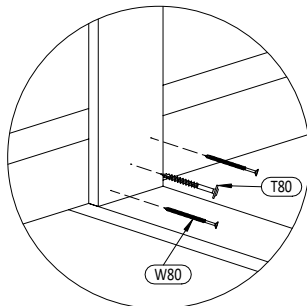

W40 x14



W80 x4

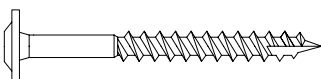

T80 x2

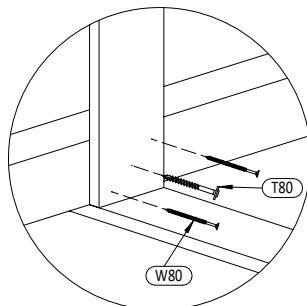

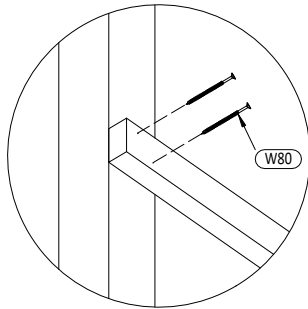
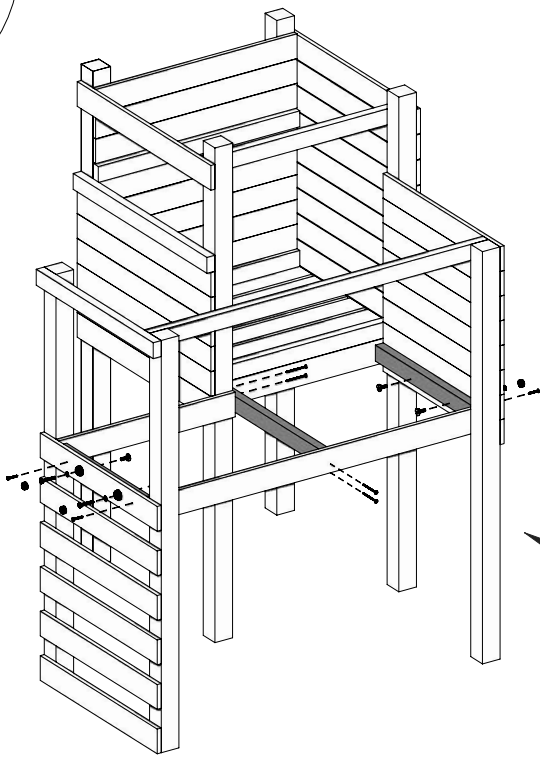
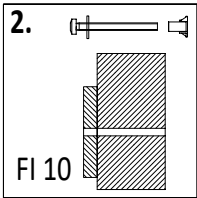
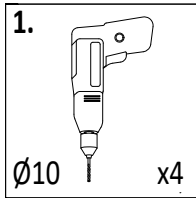
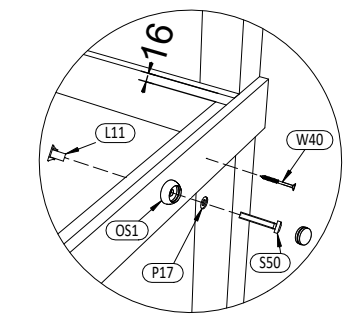

OS1 x4

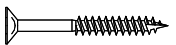

W40 x6

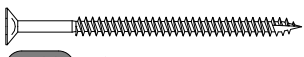

W80 x2

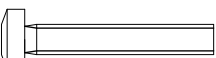

S50 x4



P17 x4



L11 x4

13 3,2x5,8x52,8cm x1

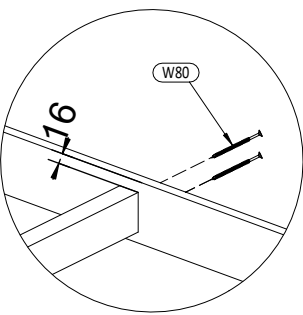

11 3,2x5,8x61cm x2

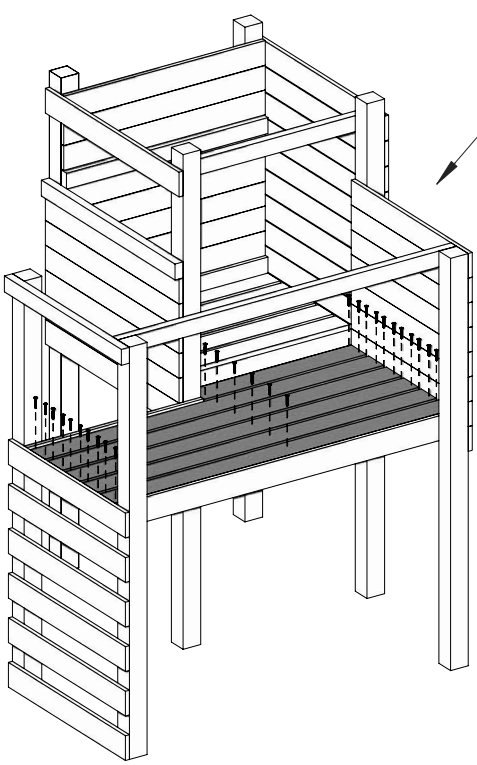
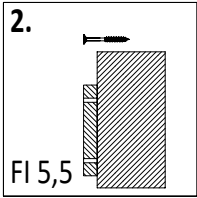
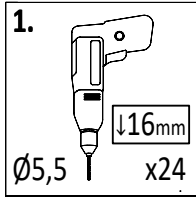

23 1,6x9,0x64,4cm x1

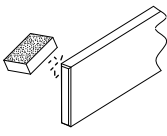

16 1,6x9,0x134,5cm x5

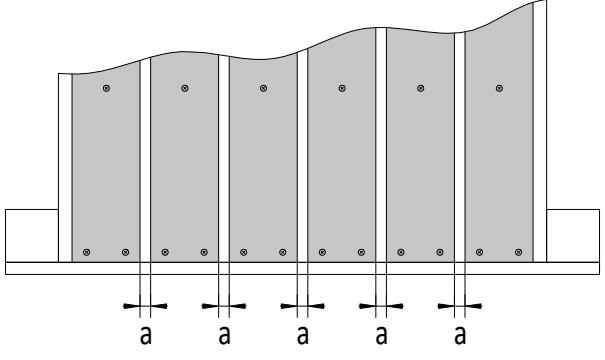

!!!min 13mm < a < !!!max 16mm

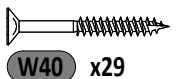

Zgodne z normą PN-EN 71 stosuj zalecenia producenta odnośnie odległości oraz metody mocowania poszczególnych elementów  
 In compliance with the standard PN-EN 71, apply guidelines of the producer in relation to distances and methods of fastening individual elements

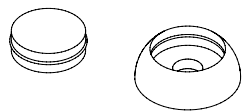
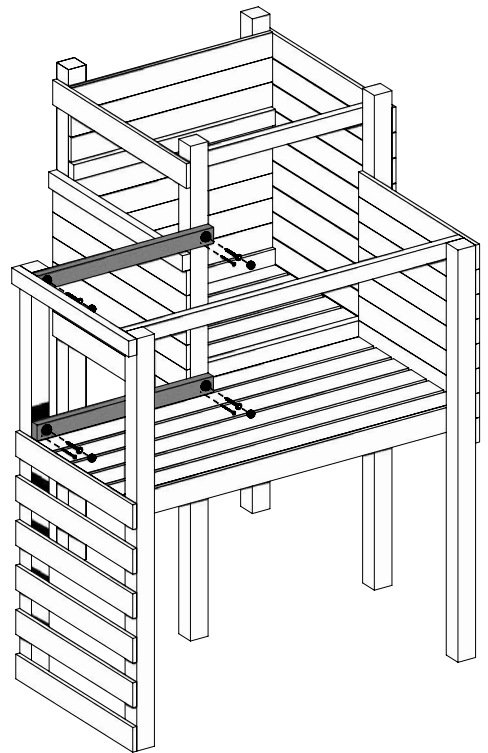
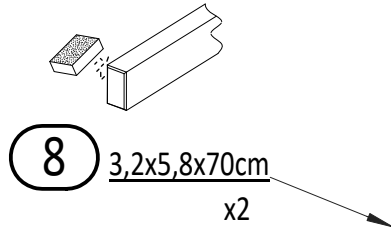
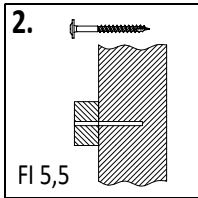
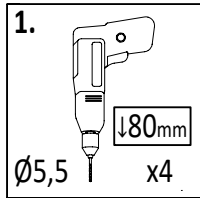

OS1 x4

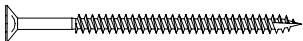

W80 x4

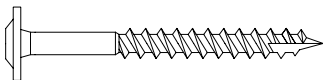

T80 x4

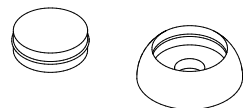
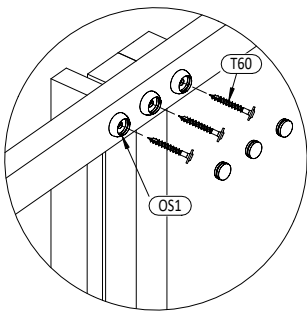
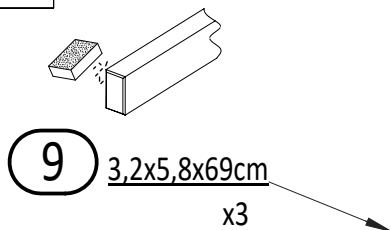
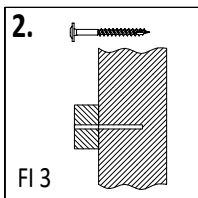
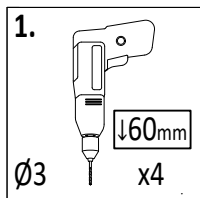
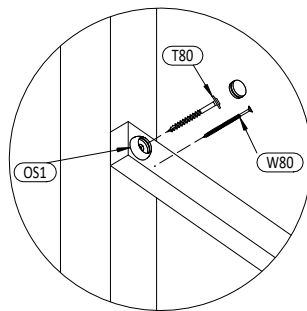

OS1 x3

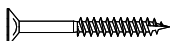

W40 x6



T60 x3

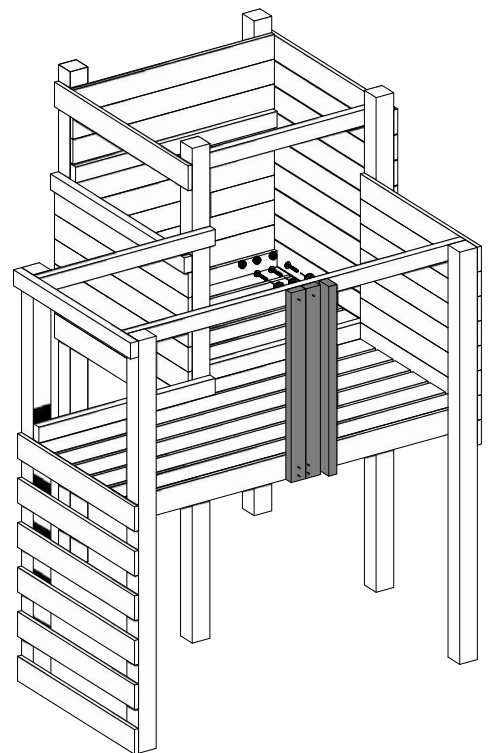
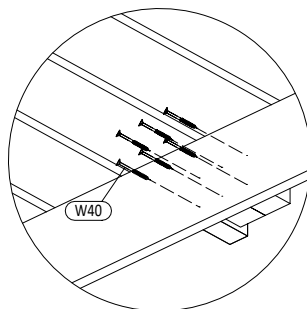

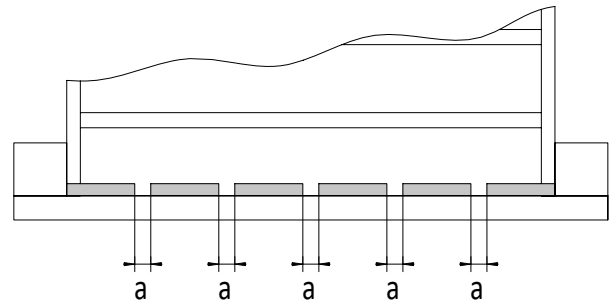
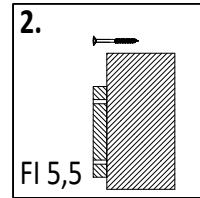
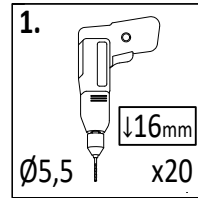
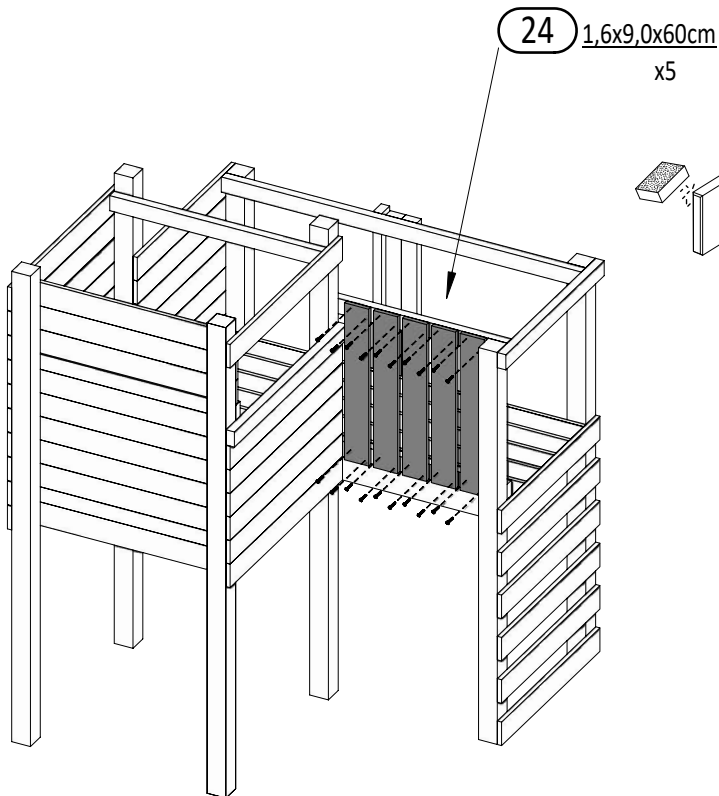

!!!min 13mm < a < !!!max 16mm

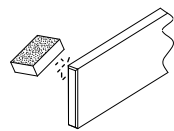
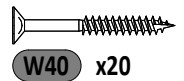

x2

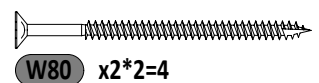
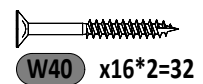
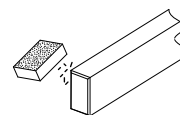
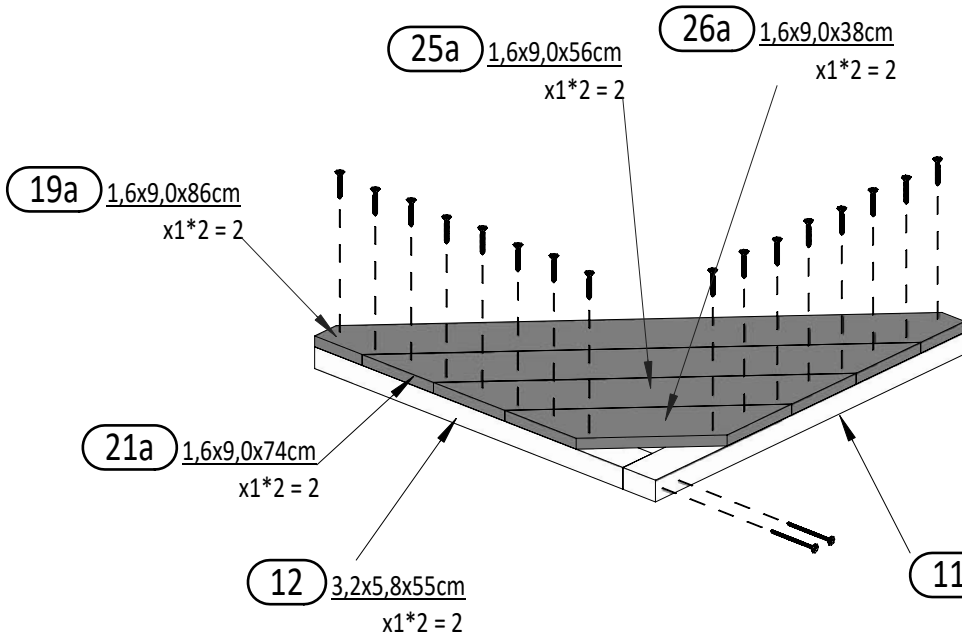
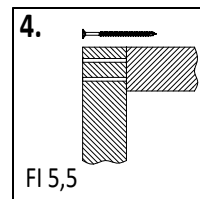
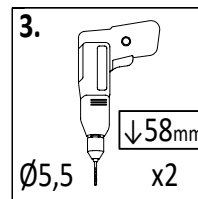
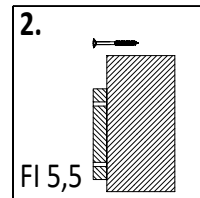
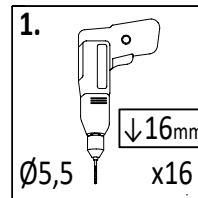

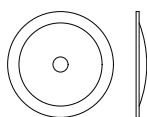
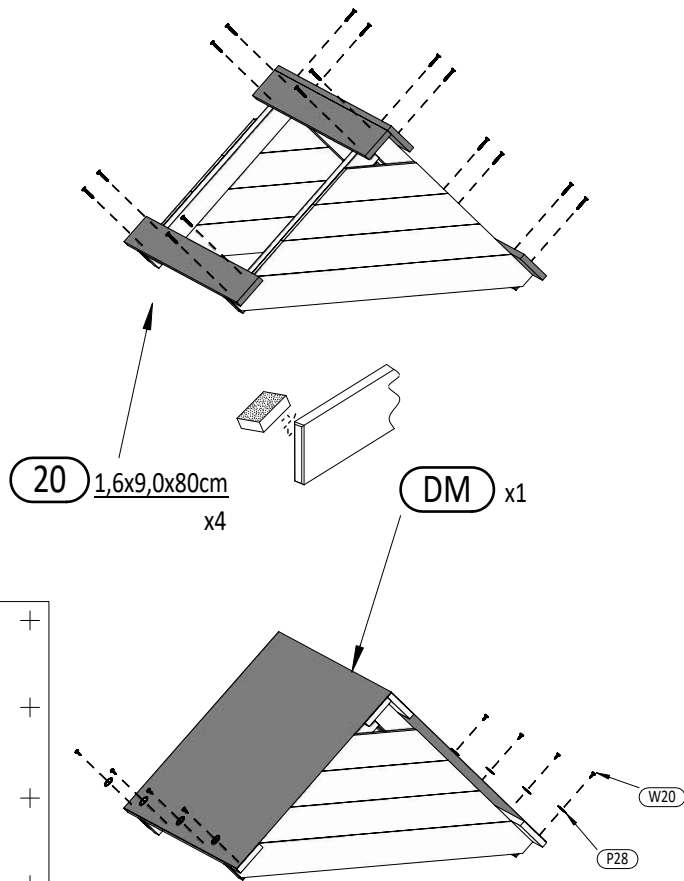
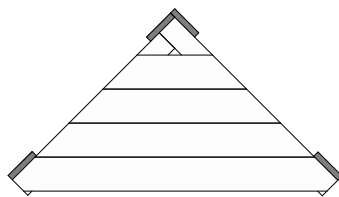
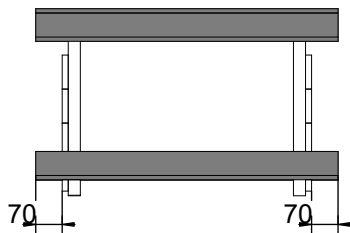
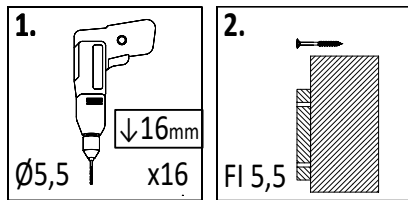

P28 x8

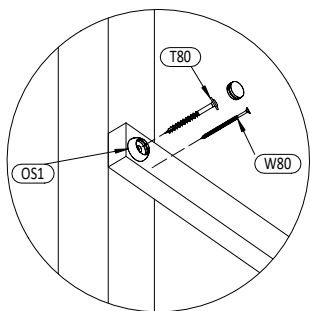
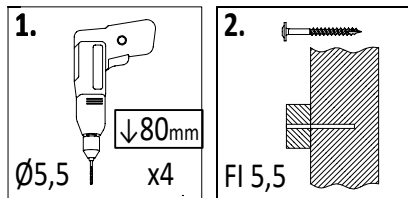
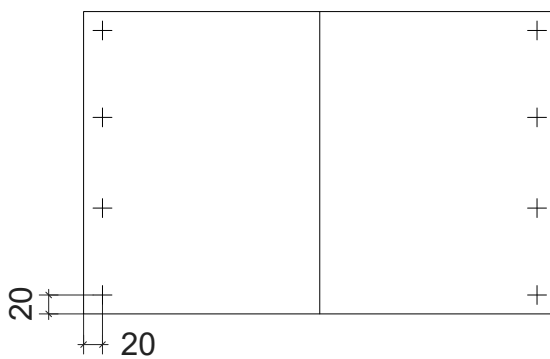
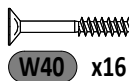
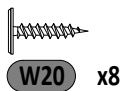

OS1 x4

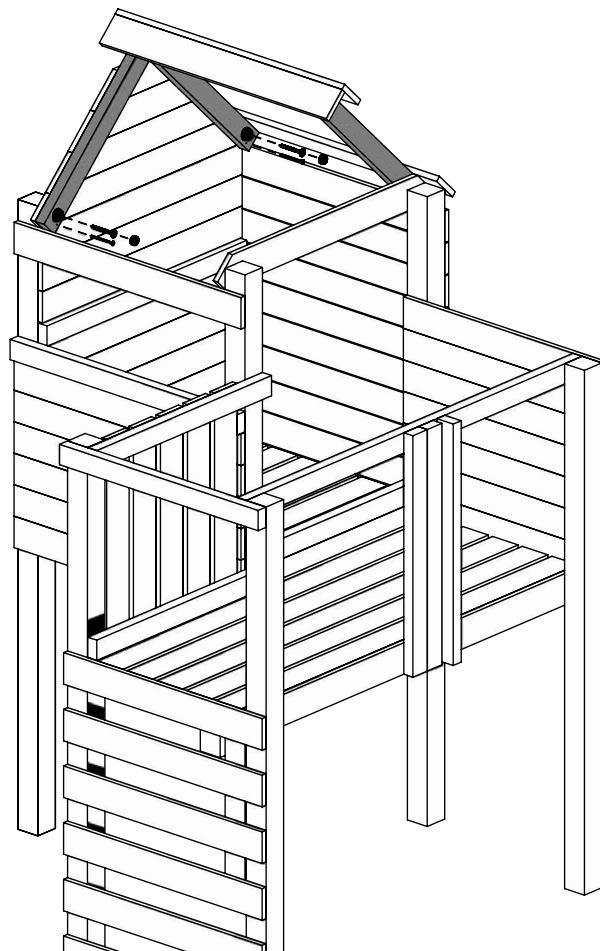
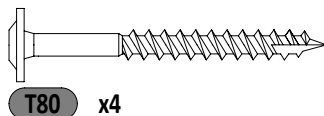
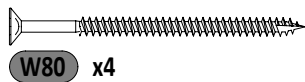

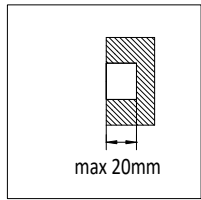

max 20mm

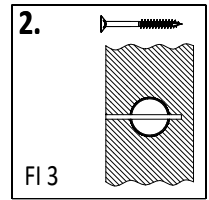
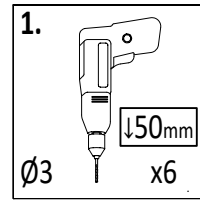
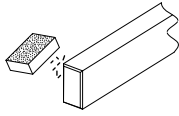

6a 3,2x5,8x94cm x2

SD x3

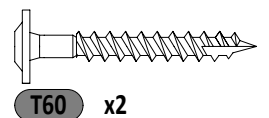
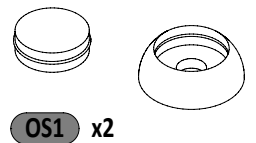
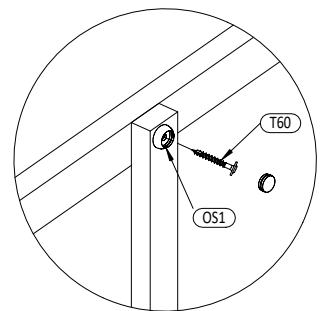
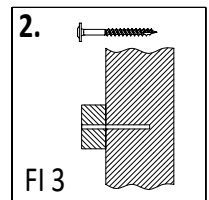
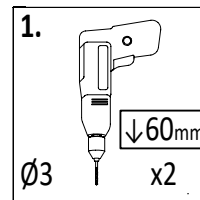
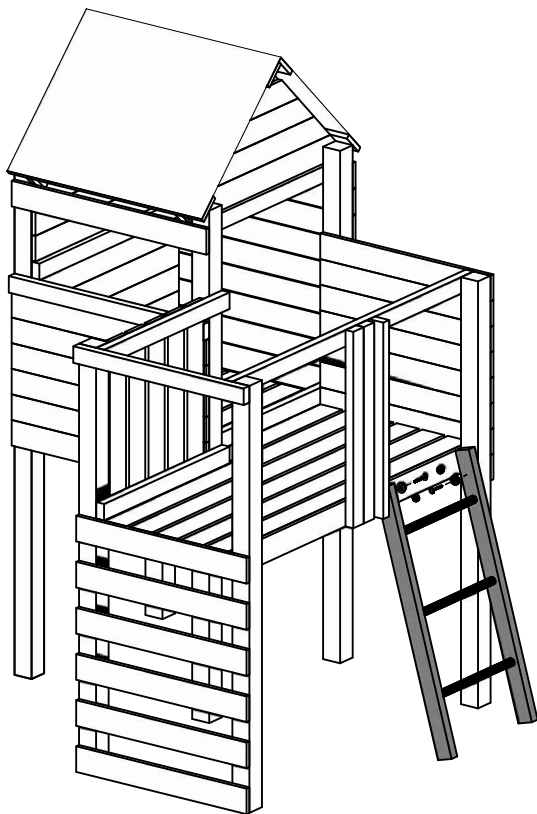
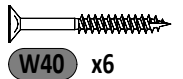
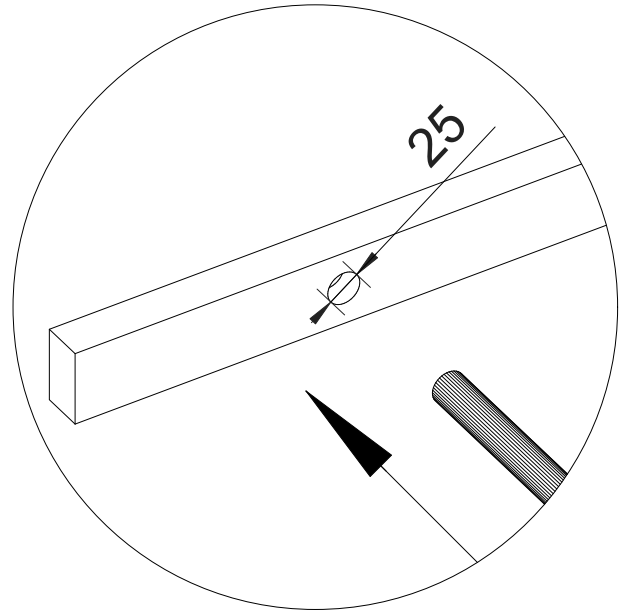
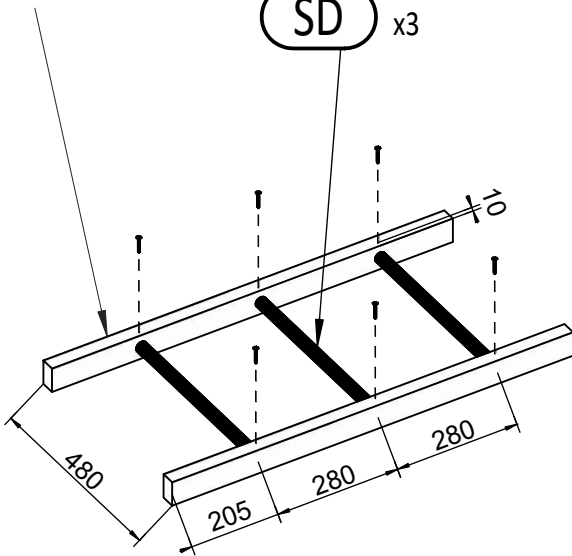

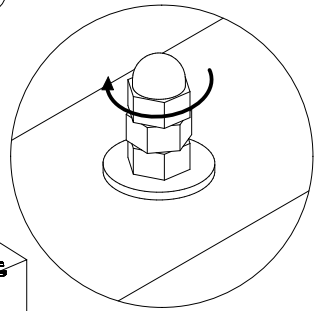
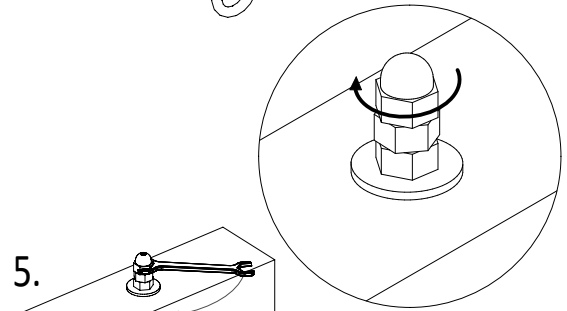
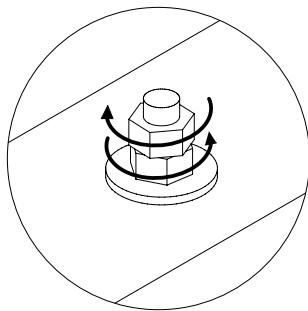
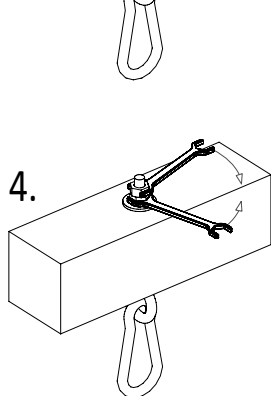
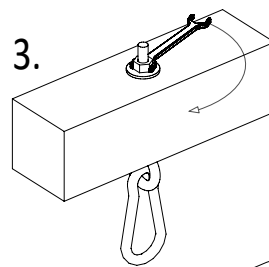
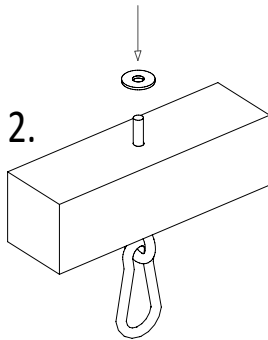
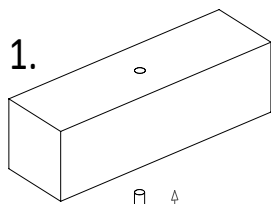
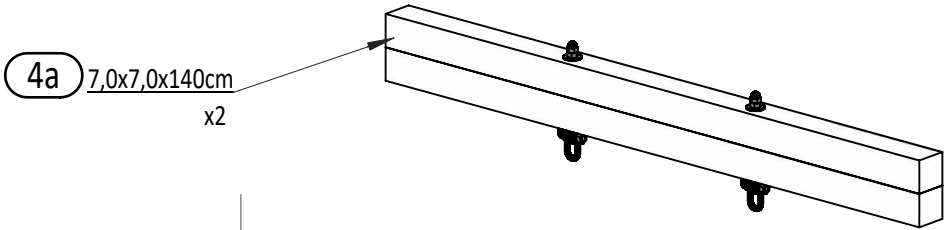

**M10** x2

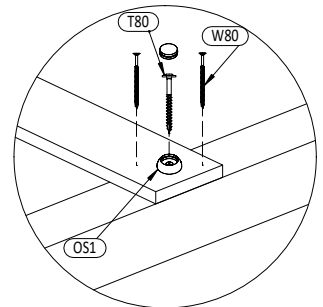
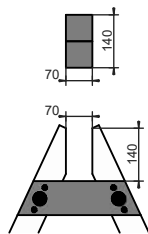
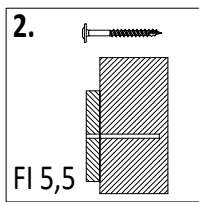
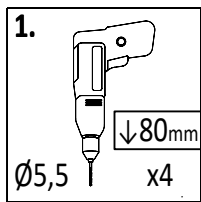

**2a** 7,0x7,0x175cm x2

**17a** 1,6x9,0x120cm x1

**27a** 1,6x9,0x32,5cm x1

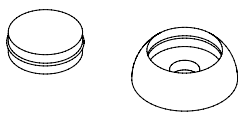

**OS1** x4

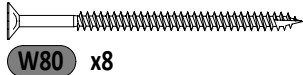

**W80** x8

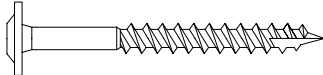

**T80** x4

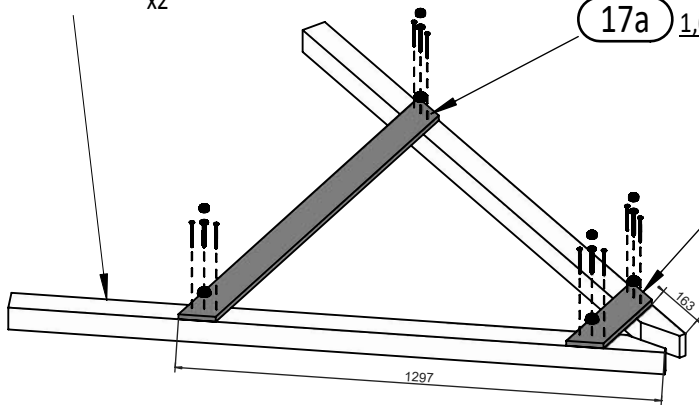

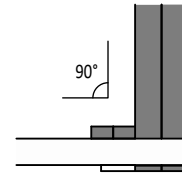
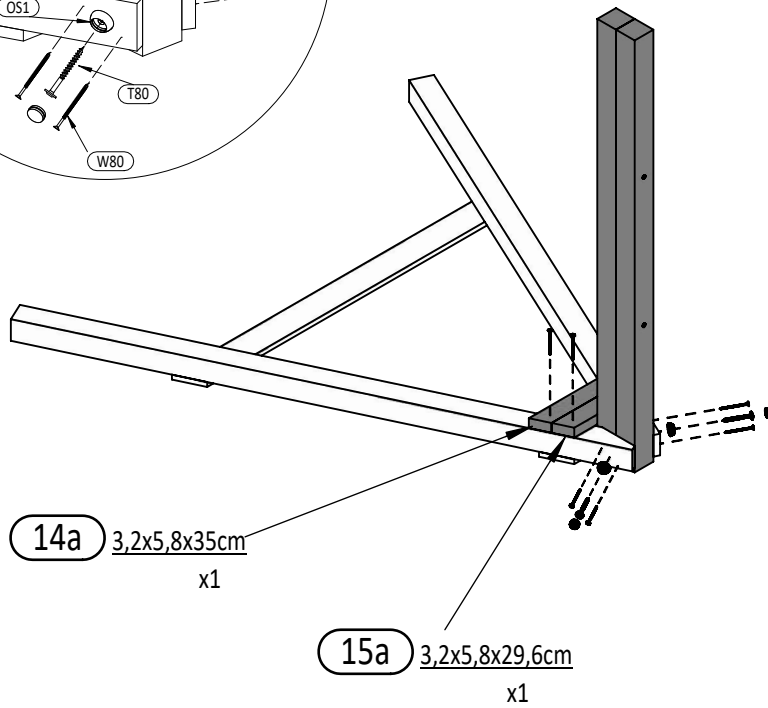
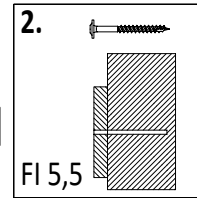
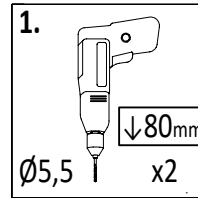
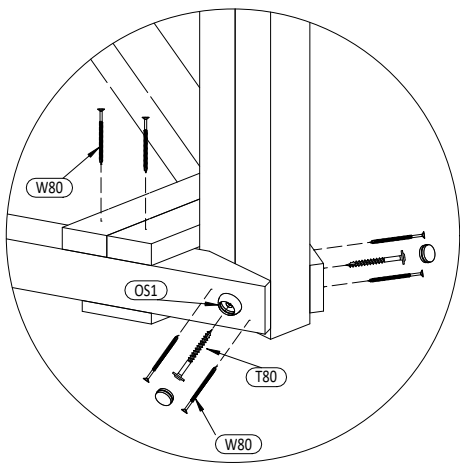

OS1 x2

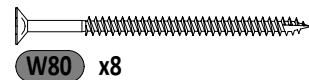

W80 x8

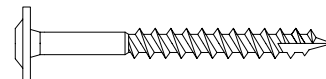

T80 x2

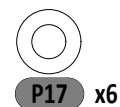
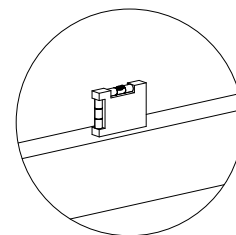
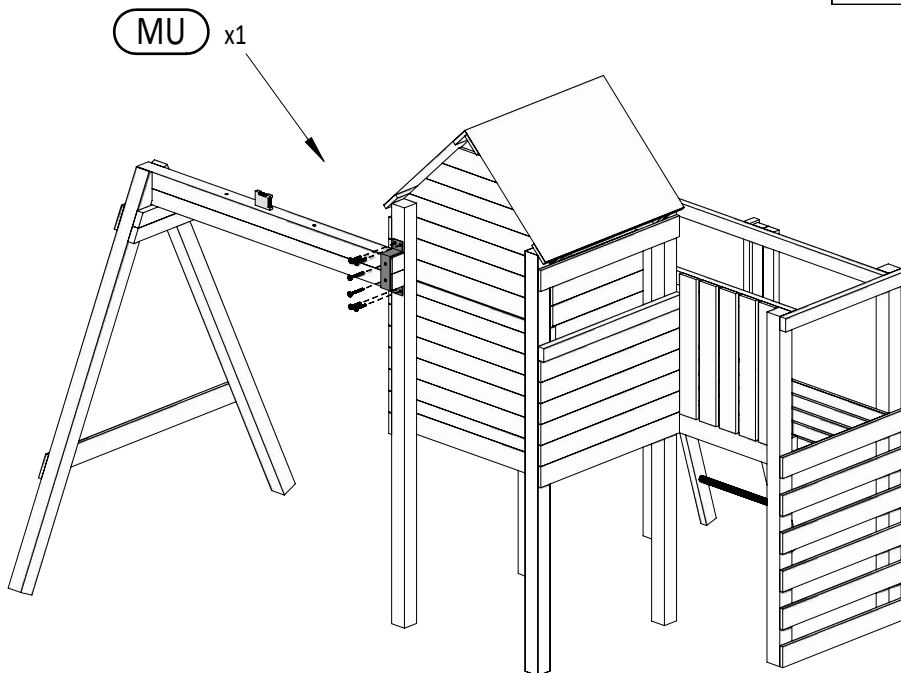
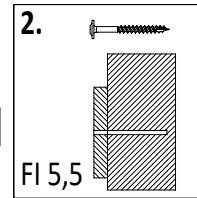
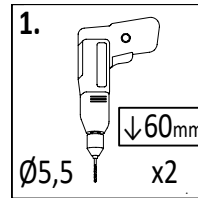

P17 x6

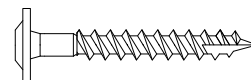

T60 x4



T80 x2

29

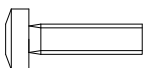
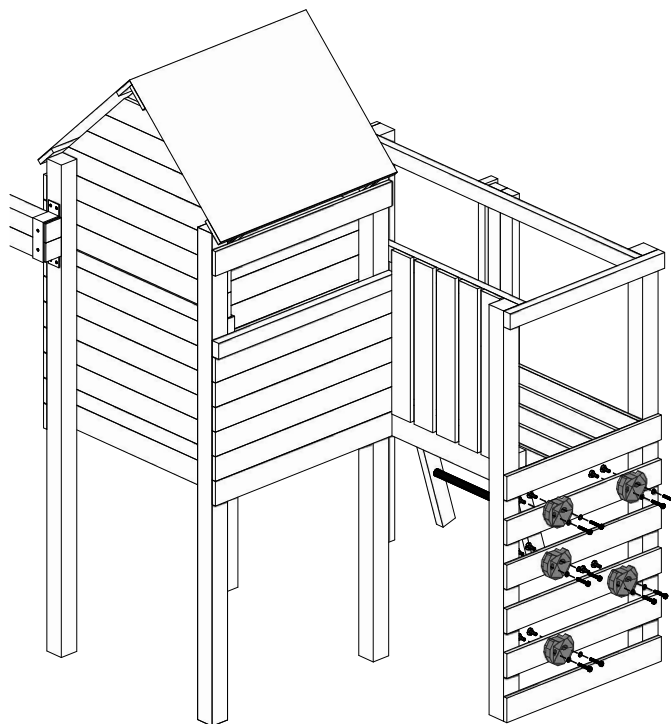
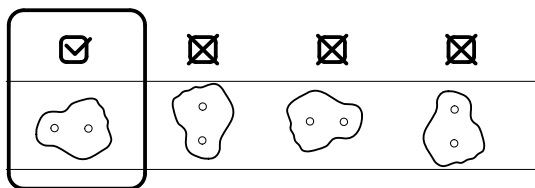
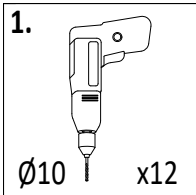

S30 x10



P15 x10

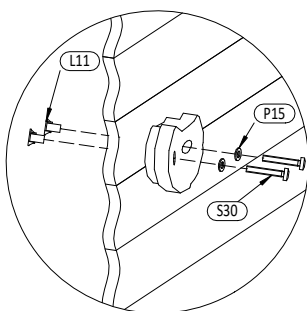

L11 x10

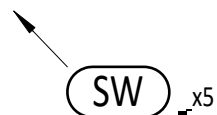

30

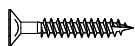
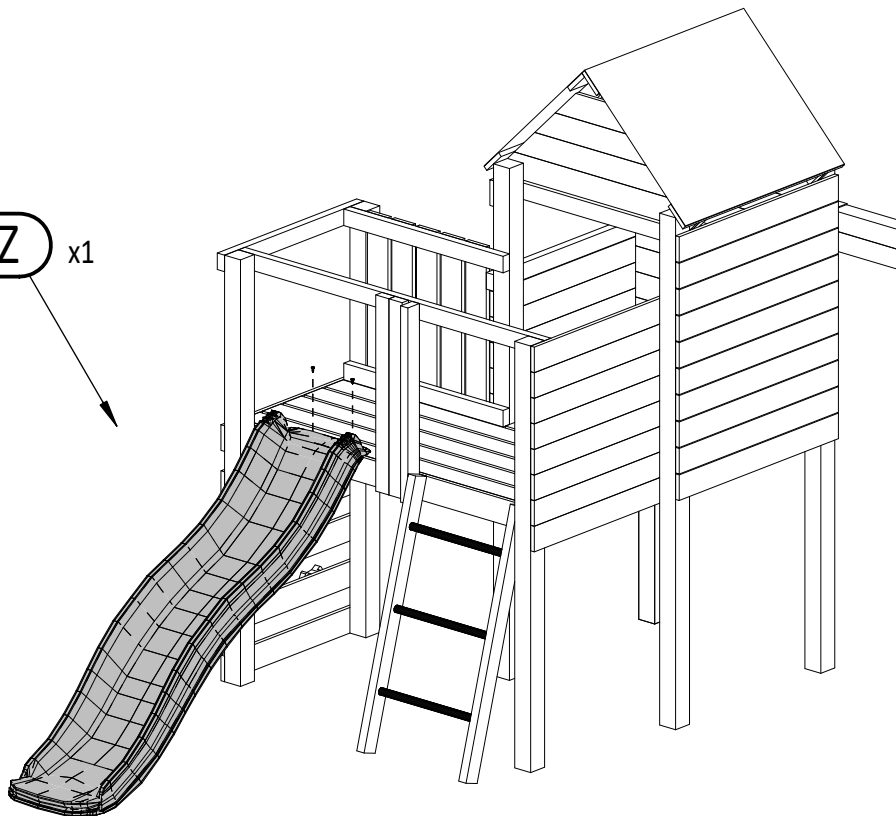
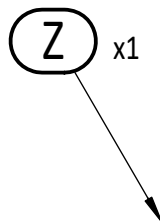
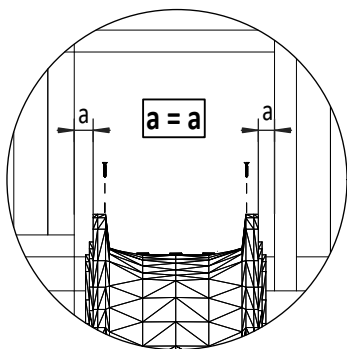

W30 x2

UC x4

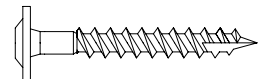
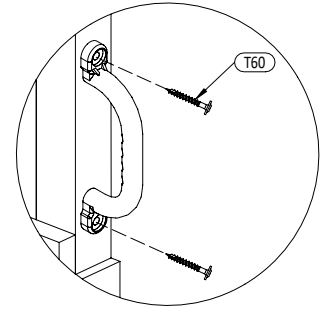
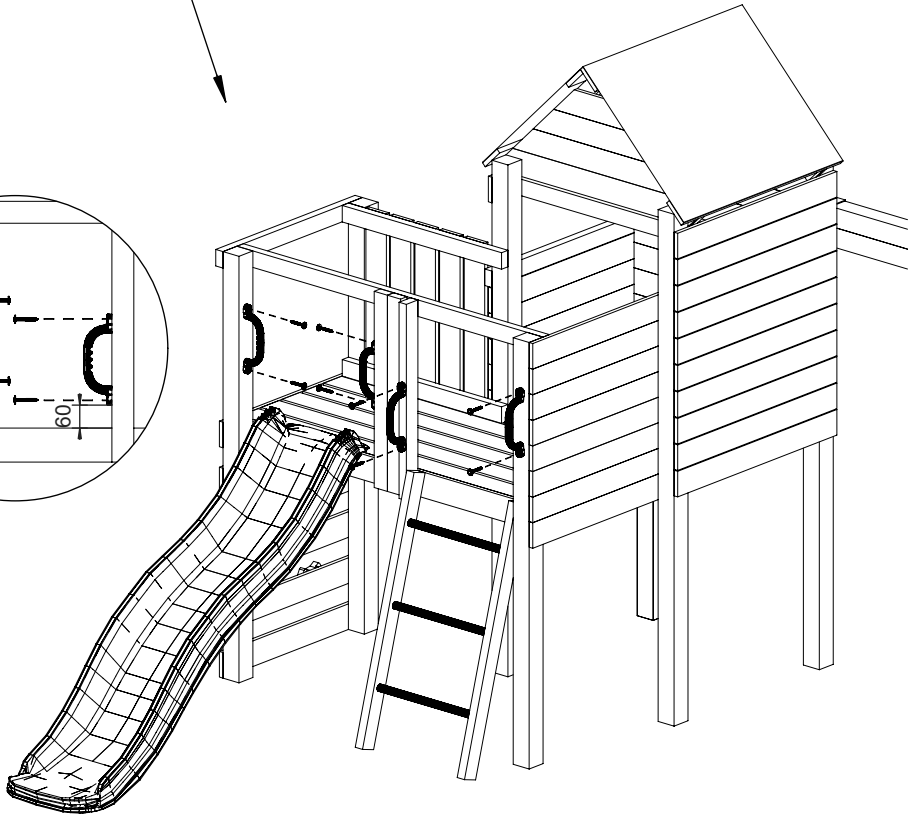
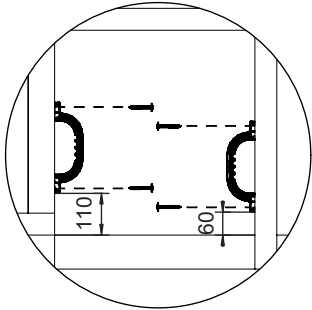

T60 x8

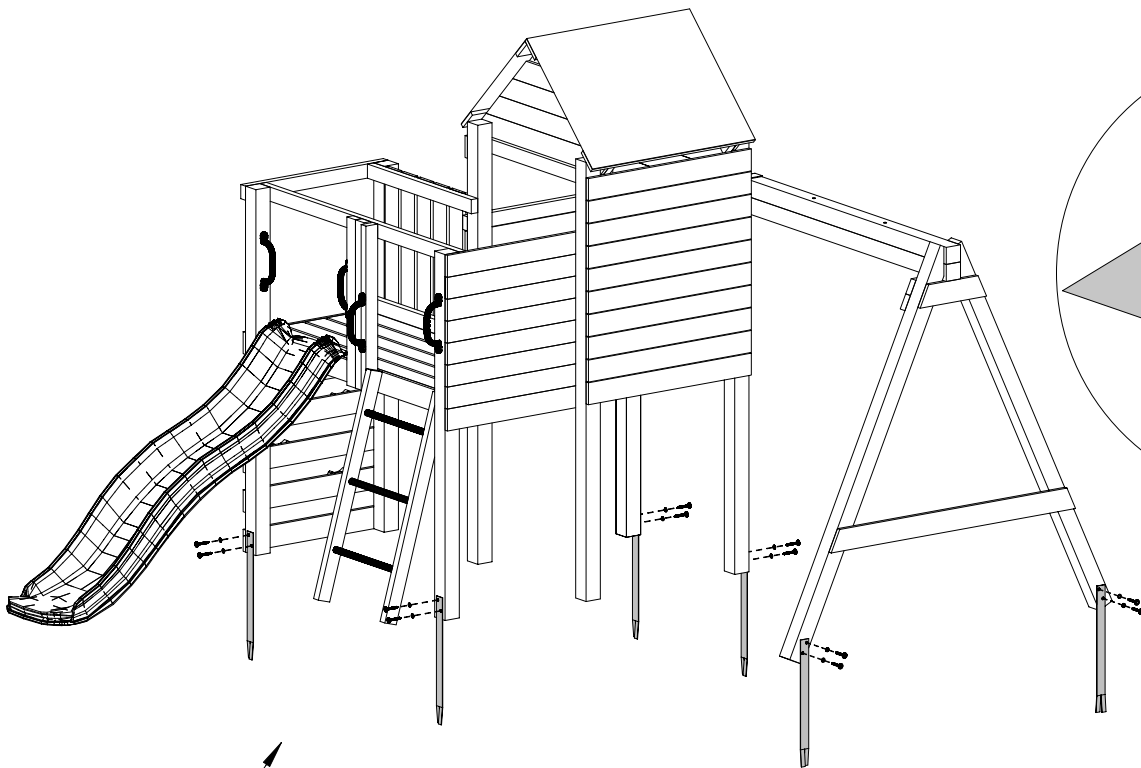
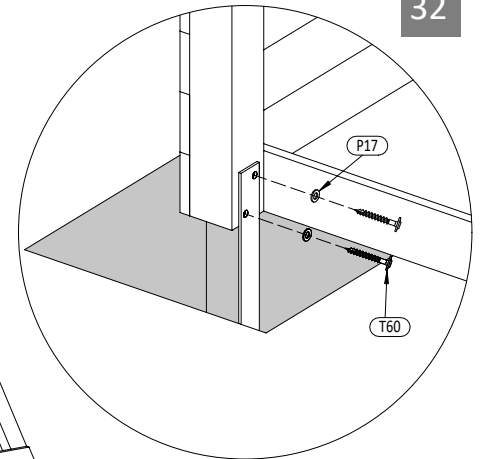

MG x6

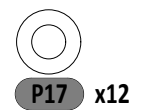

P17 x12

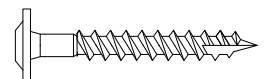

T60 x12

Zgodnie z normą PN-EN 71 stosuj zalecenia producenta odnośnie odległości oraz metody mocowania poszczególnych elementów  
 In compliance with the standard PN-EN 71, apply guidelines of the producer in relation to distances and methods of fastening individual elements

33

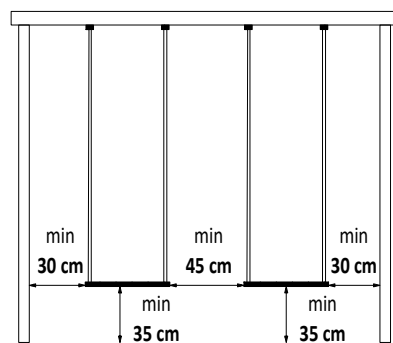
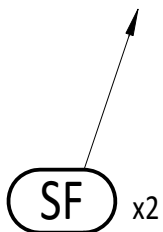
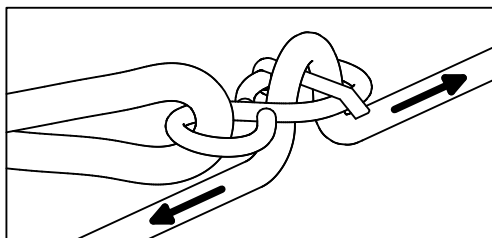
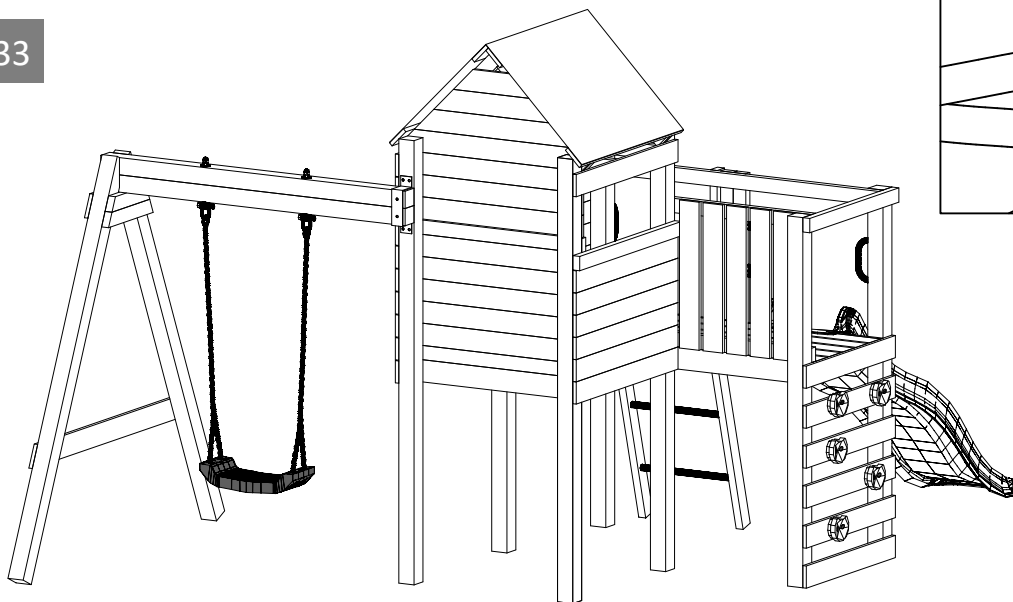

34

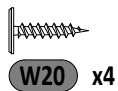
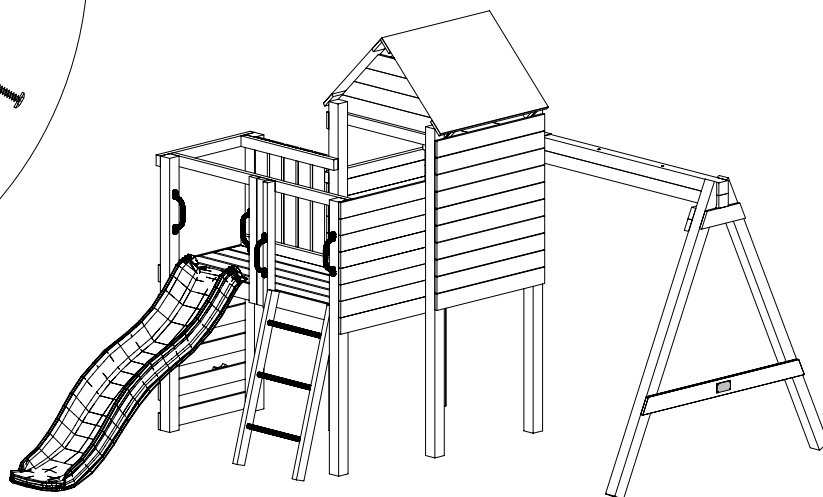
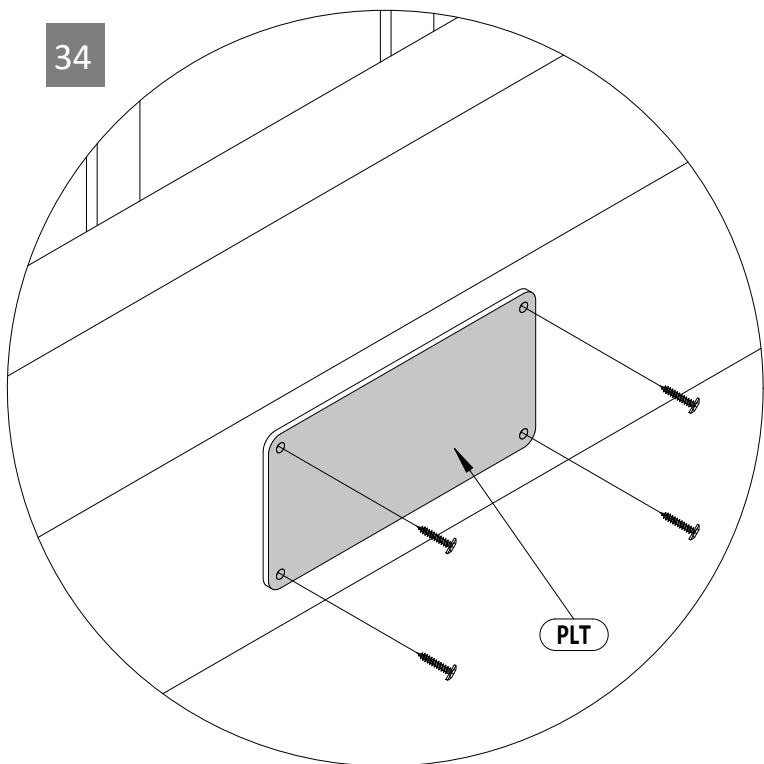

24

BIBALU

Zgodnie z normą PN-EN 71 stosuj zalecenia producenta odnośnie odległości oraz metody mocowania poszczególnych elementów  
 In compliance with the standard PN-EN 71, apply guidelines of the producer in relation to distances and methods of fastening individual elements

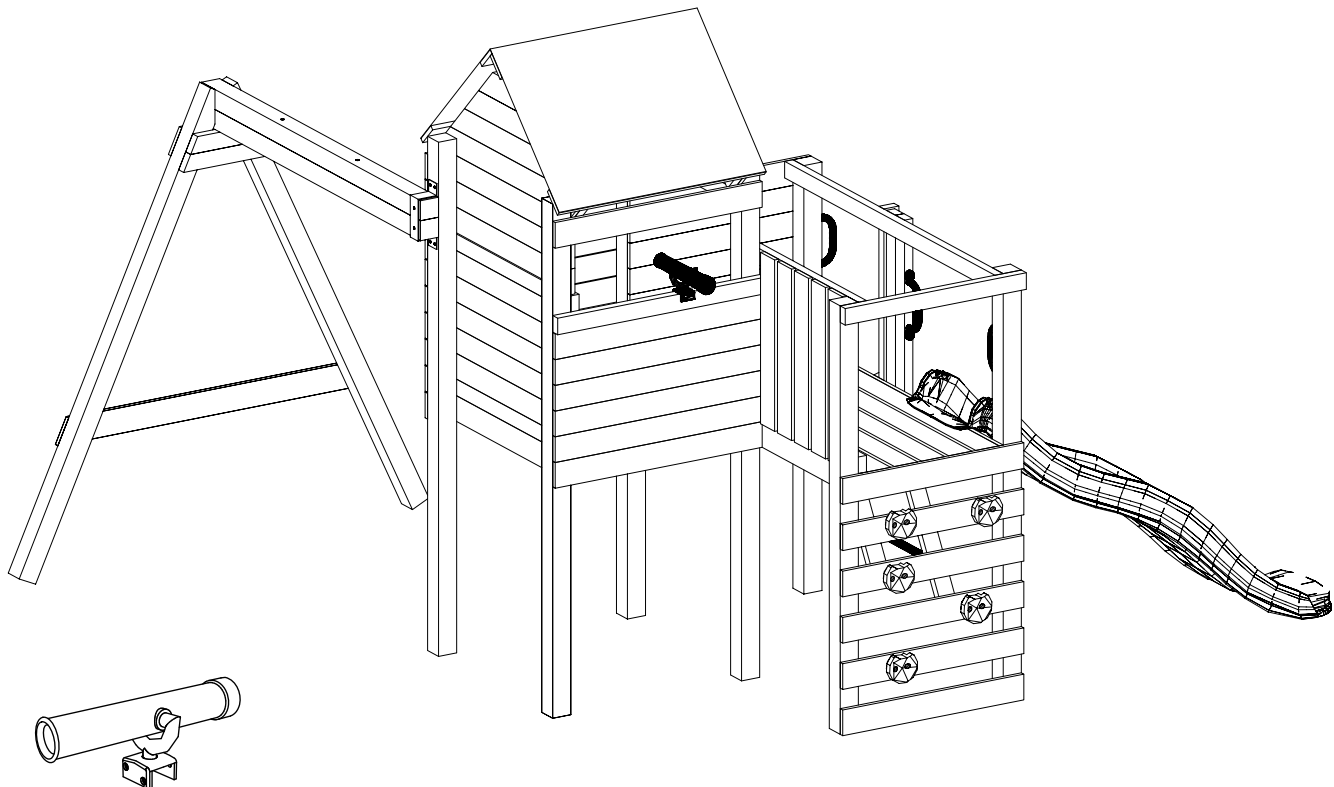

↑  
TS x1